

USER'S GUIDE

Installation & Operation
Instructions

Area-Velocity Flow Meter
Model AVFM-II
Manual Series A.12

Note: This page has been left blank intentionally.

INDEX

Function Test	4
Connections	4
Keypad System	4
Menu - Flow Chart	5
Run	7
Totalizer	8
Password	8
Units / Mode	9
Calibration - for Open Channel Flow	12
4-20mA Outputs	13
Relay Parameters	14
Special Functions	15
Sensor Location	17
Enclosure Installation	21
Field Troubleshooting	23
Sensor Cleaning Instructions	24
Applications Hotline	25
Product Return Procedure	26
Warranty	27
Appendix A - Options	28
Data Logger	34
RS232C Serial Output	40
Conversion Guide	42
Specifications	43

IMPORTANT NOTE: This instrument is manufactured and calibrated to meet product specifications. Please read this manual carefully before installation and operation. Any unauthorized repairs or modifications may result in a suspension of the warranty.

Available in Adobe Acrobat pdf format

INTRODUCTION:

The Greyline AVFM-II Area Velocity Flow Meter measures open channel flow in pipes and other channels. Flow calculation is based on the formula: $Q = V \times A$. Q is flow, V is velocity, and A is the cross-sectional area of flow volume in the pipe or channel.

The AVFM-II measures both level and velocity continuously. Level readings plus the user-entered diameter or channel width are used to calculate the cross-sectional area. Combined with velocity readings the AVFM-II measures the flow rate.

FUNCTION TEST:

Connect the sensor to the **TDCR** terminals as shown below, then apply power. Allow 30 seconds for the AVFM-II to initialize.

- A. Place QZ02L sensor (flat to the bottom) in a bucket of water about 6" deep and select **Level 1** mode (from **UNITS/MODE** menu) to see a level reading.
- B. Select **Velocity** mode and stir the water to see a velocity reading.

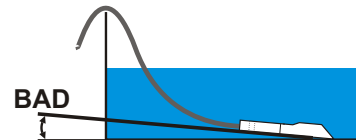
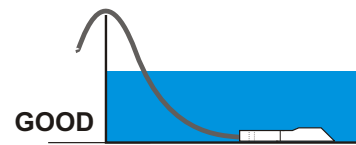

CONNECTIONS:

POWER INPUT: The standard model requires AC power input between 100-130VAC 50/60Hz (2 amp fuse is recommended). No adjustments are necessary for any voltage in this range. Optional 230VAC requires power input between 200-260VAC 50/60Hz. (See **OPTIONS** section of this manual for connection of optional 9-36VDC power input).

IMPORTANT NOTE: To comply with CSA/NRTL standards, AC power input and relay connection wires must have conduit entry to the instrument enclosure.

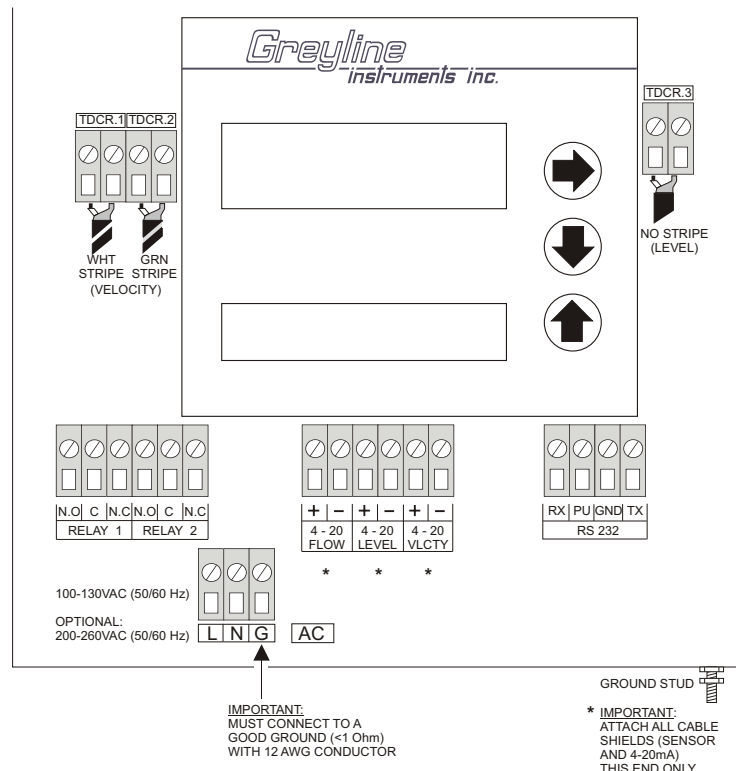

KEYPAD SYSTEM

The AVFM-II has a simple 3-button calibration system. Operating and calibration modes are shown on the 16-digit alphanumeric display. The keypad is used to move around the menu to calibrate the AVFM-II, and to view operating mode and functions. A beep is sounded as each key is pressed. If the keypad is not used for 2 minutes, the AVFM-II will automatically go to RUN mode (scrolling display). Use the keypad to explore the Menu and become familiar with its features.

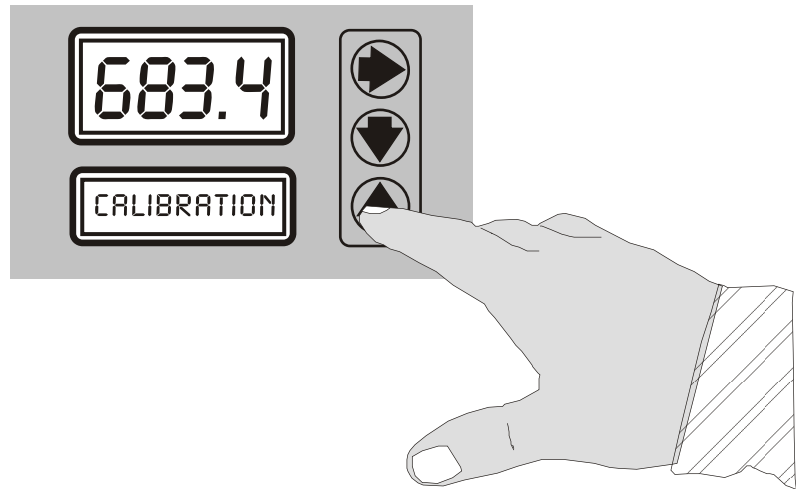

MENU - FLOW CHART

The following diagram shows part of the AVFM-II Menu system. Arrows show the three directions to leave a box. Pressing a corresponding keypad arrow will move to the next box in the direction shown. Move the cursor (or underline) under numerals to increase or decrease the number with the \downarrow \uparrow keys.

At the bottom of each Menu column is a Store? Yes box. To store the calibration values permanently (even through power failure), move the cursor under Yes and press the \downarrow or \uparrow key. If the \downarrow key is pressed with the cursor under Store? no changes will be stored and the system will return to the top of the Menu column.

AVFM-II - CALIBRATION MENU

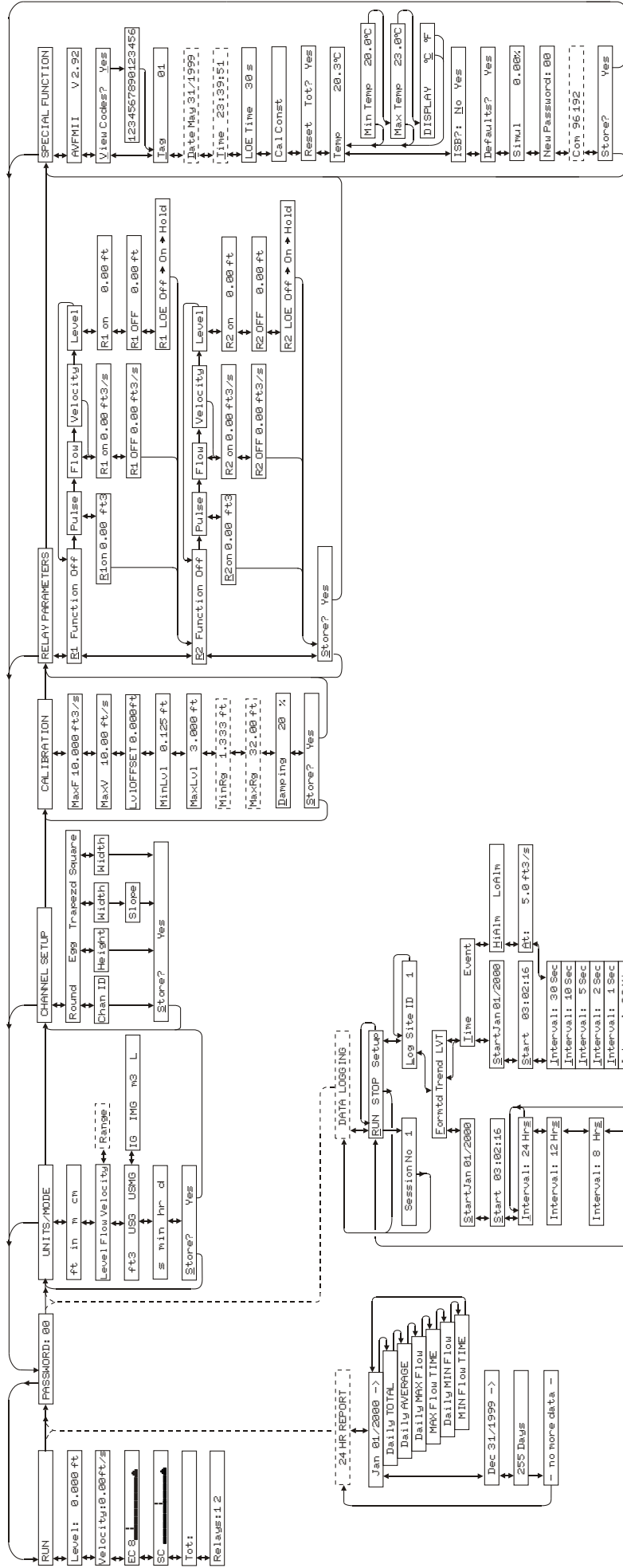

OPTIONAL FEATURES

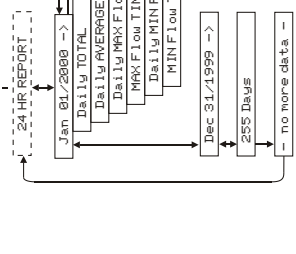
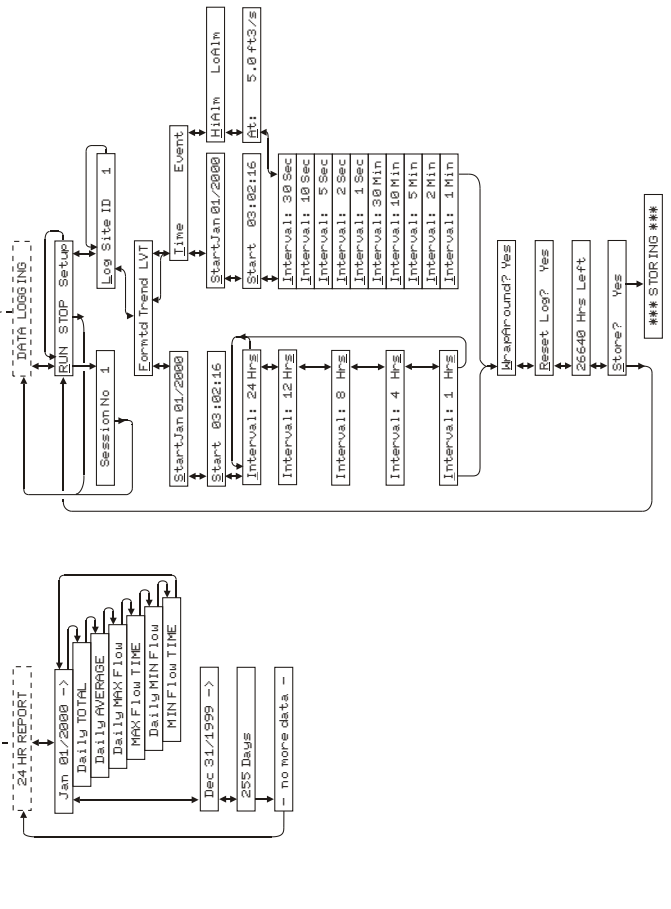

RUN

A scrolling display shows the units selected from the UNITS/MODE column, the maximum value in the mode being displayed (Level, Flow or Velocity), the Totalizer value, and the logging status if that option is enabled.

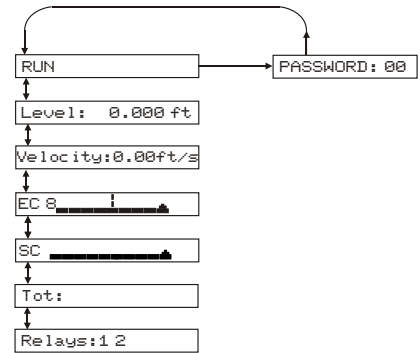

LEVEL READING

From RUN use ↓ to view Level. View the level of fluid measured by the instrument.

VELOCITY READING

From RUN use ↓↓ to view Velocity. View the velocity of fluid measured by the instrument.

ECHO CONFIDENCE - Level

From RUN use ↓↓↓ to view Echo Confidence, EC. This indicator displays the echo strength for the level measurement.

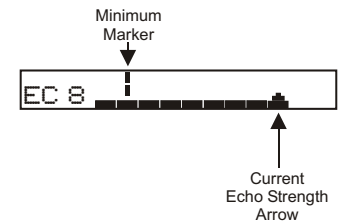

SIGNAL CONFIDENCE - Velocity

<p>From Run use ↓↓↓↓ to view Signal Confidence, SC. This indicates consistent or widely varying flow rates and helps gauge the quality of the velocity signal in the application.</p>	
<p>Press → to position the cursor under the numeral. Use ↑ or ↓ to increase or decrease signal confidence. Minimum setting is '1' Maximum setting is '9'.</p>	
<p>Signal confidence should be adjusted so that the 'Signal Confidence Arrow' meets the 'Ideal Marker' under normal flow conditions.</p>	
<p>Signal strength must pass the 'Minimum Marker' for the flow meter to display flow.</p>	
<p>It is normal for Signal Strength to fluctuate and rise to full scale under high flow conditions.</p>	

TOTALIZER

From RUN use ↓ or ↑ keys to display Tot: value. The Totalizer value is updated every 2 seconds with flow volume > 1 litre (0.264 USG). The display will show up to 10 digits and then restart at 0 automatically.

Units: ft³, USG, IG, L T: 9999999999 → TOT: 0

Units = m³ T: 0283168470 → TOT: 0

Press ↓ or ↑ keys to return to RUN.

The totalizer can be reset to zero by going to SPECIAL FUNCTION and ↓ to Reset Tot?.

RELAY STATUS DISPLAY

Press ↓ from Tot: to RELAYS 1,2.

Energized relays will be displayed in reverse type RELAYS: 1 2

PASSWORD

The password (a number from 00 to 99) prevents unauthorized access to the CALIBRATION menu.

From RUN (scrolling display) press → to PASSWORD.

Press → to place the cursor under the digits and ↓ or ↑ to change the number and then → to proceed to CALIBRATION.

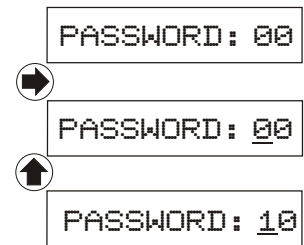

Factory default Password is 00. A new password can be stored by going → to SPECIAL FUNCTION and ↓ to New Password.

UNITS / MODE

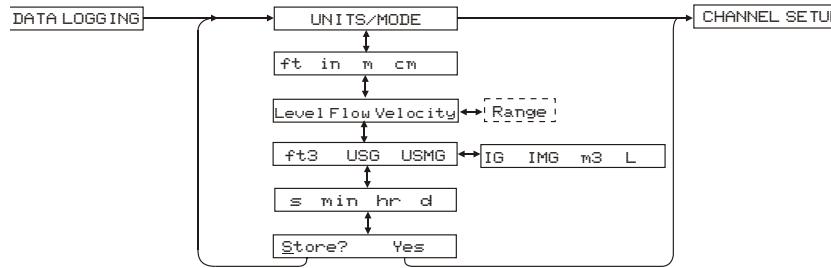

Press **➡** to UNITS/MODE, then **⬇**. Press **➡** to move the cursor under the required measurement units:

- ft - feet
- in - inches
- m - meters
- cm - centimeters
- % - percent

Press **⬇** to Level Flow Velocity > Range. Use **➡** to select the operating mode of the AVFM-II.

- Level mode measures water level above the calibrated zero level.
- Flow mode is for open channel flow in pipes or rectangular channels. Displays flow in engineering units.
- Velocity mode displays flow velocity in units/time (eg: ft/sec/ or m/sec).
- Range mode displays distance from the sensor to the liquid surface like a tape measure. (PZ12-LP option only)

Press **⬇** to make your selection.

- ft3 - cubic feet
- USG - US gallons
- USMG - US million gallons (FLOW only)
- IG - Imperial gallons
- IMG - Imperial million gallons (FLOW only)
- m3 - cubic meters
- L - liters

Press **➡** to position the cursor underneath your selection and press **⬇** to make your selection.

Repeat for selection of time units:

- s - seconds
- min - minutes
- hr - hours
- d - day

Note: The AVFM-II will display Er: ILLEGAL UNITS if your choice of Units exceeds a maximum value of 9,999,999. Use US MGD, Imp MGD, or m3/d so that Units will be 9,999,999 or less. Press **⬇** to Store and **➡** to Yes. Then press **⬇** or **⬆** to store all your UNITS/MODE selections.

CHANNEL SETUP

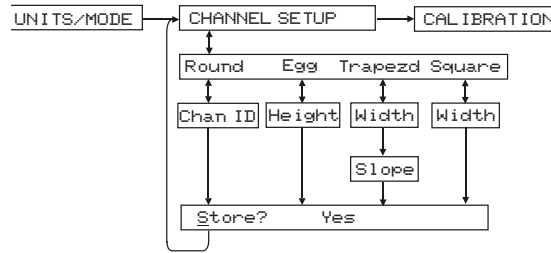

From CHANNEL SETUP press ↓ to Round Egg Trapezd Square.

Round Select Round for open pipes. Press ↓ to Chan ID and ➡ to edit the channel/pipe inside diameter. Use ↓ and ↑ to change the numbers and decimal point.

Egg Select Egg for channels with cross-section dimensioned as shown. Press ↓ to Height and ➡ to edit the channel height. Press ↑ and ↓ to change numbers and decimal point.

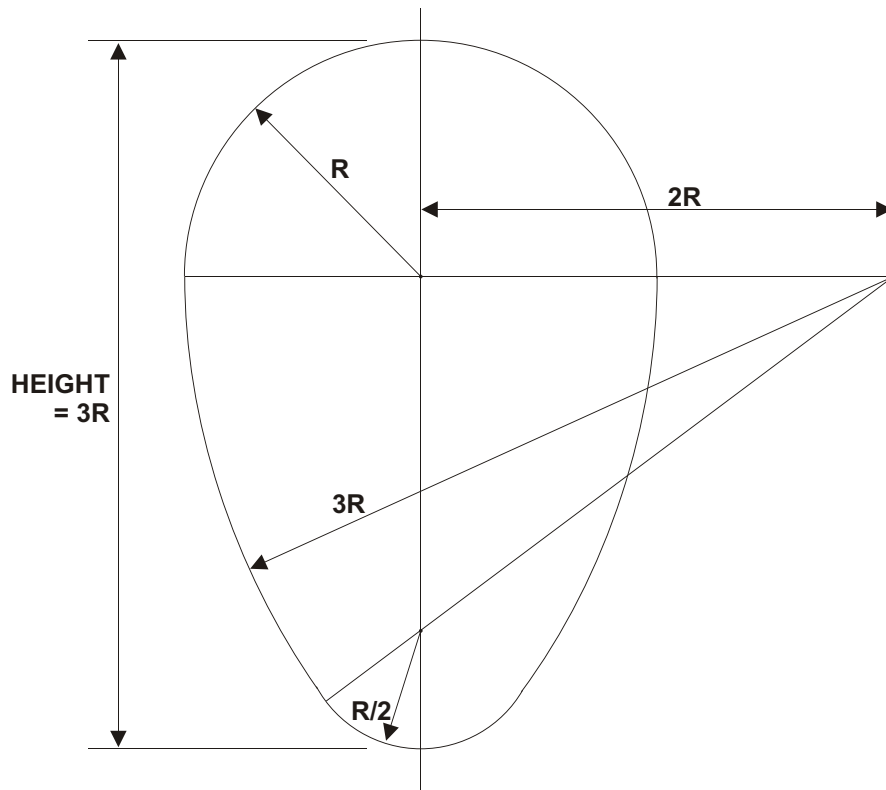

Trapezoid Select Trapezd for trapezoidal shaped channels. Press \downarrow and enter Width and \downarrow and enter Slope

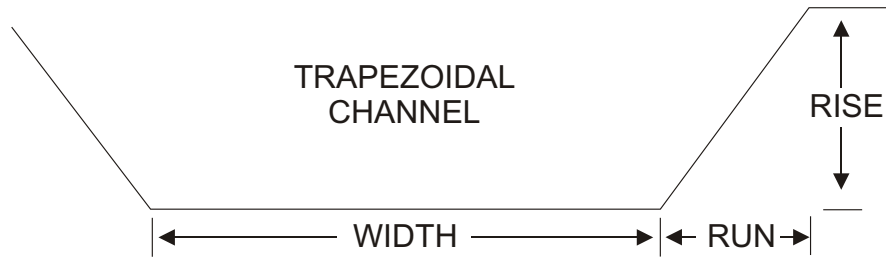

$SLOPE = \frac{RISE}{RUN}$					
e.g.#1	WIDTH =	24"	e.g.#2	WIDTH =	1 m
	RUN =	10"		RUN =	0.35 m
	RISE =	12"		RISE =	0.5 m
SLOPE =	$\frac{RISE}{RUN}$ =	1.2	SLOPE =	$\frac{RISE}{RUN}$ =	1.429

Note - V shaped channels may also be monitored where the channel width is entered as 0.

Square Select Square for rectangular channels. Press \downarrow to Width and \rightarrow to edit the channel width. Use \downarrow and \uparrow to change the numbers and decimal point.

When channel type and all units have been selected press \downarrow to Store? and then \rightarrow to Yes and \downarrow or \uparrow to CALIBRATION.

CALIBRATION

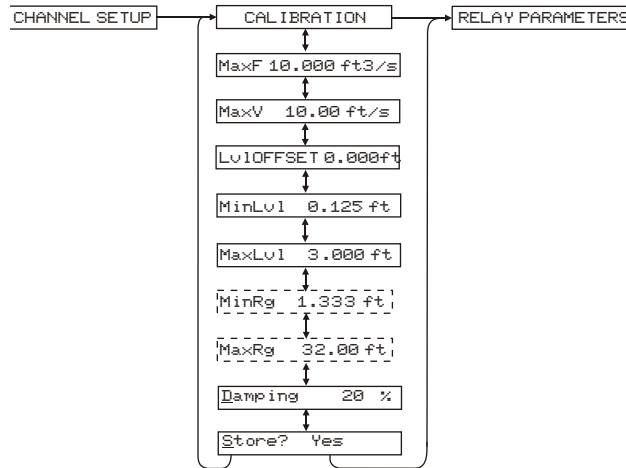

From CALIBRATION press **↓** to MaxF. Enter the maximum expected flow in your application. If the maximum expected flow is unknown, enter an estimated value.

Note: MaxF entry is *only* required to calibrate 20mA output at your maximum flow rate.

Press **↓** to MaxV. Enter the maximum expected flow velocity in your application. If the maximum velocity is unknown, enter an estimated value, e.g. 10 ft/s.

Note: MaxV entry is only required to calibrate velocity at 20mA output and to set the maximum velocity measured in LVT logging mode.

Press **↓** to LV10FFSET. Set to 0.00 when sensor is mounted on the floor of the channel. When sensor is mounted above the floor of the channel enter the distance between channel floor and bottom of sensor.

Note: 4mA is not affected by LV10FFSET settings. 4mA is the bottom of the channel or pipe.

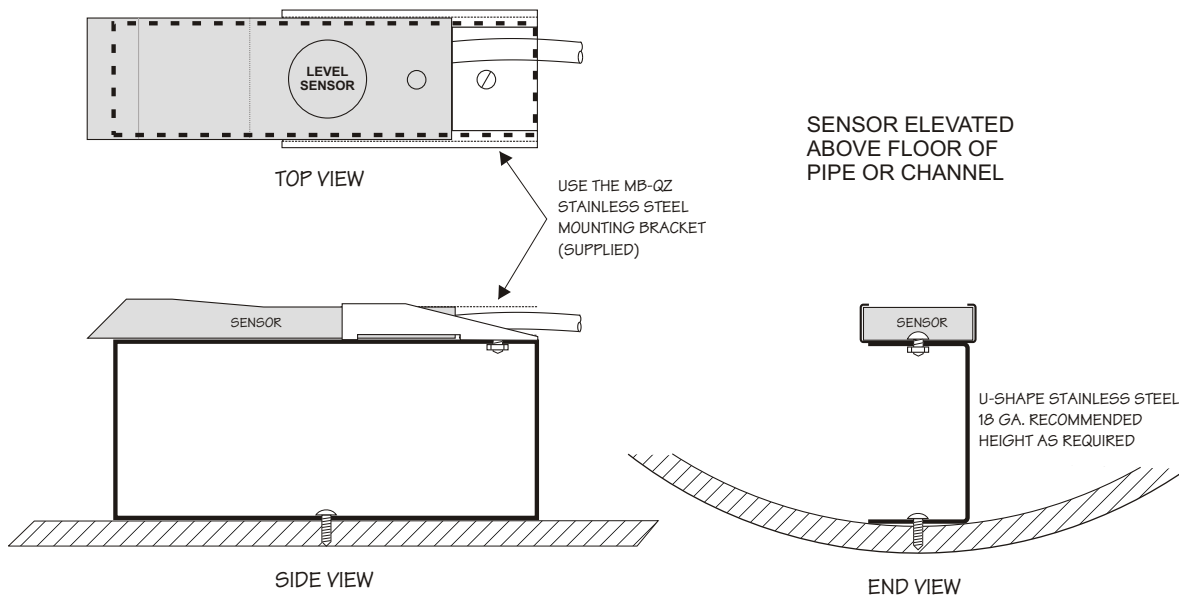

Press **↓** to **MinLv1**. Minimum level threshold. When the fluid “head” drops below **MinLv1** the flow measurement is forced to zero (4mA). **MinLv1** can be set between 1” and 6” (25.4 and 152.4 mm) above **Lv1OFFSET** setting.

Press **↓** to **MaxLv1**. Enter the maximum expected level in your application. If the maximum level is unknown, enter an estimated value, e.g. 6 ft.

Note: **MaxLv1** entry is only required to calibrate the level at 20mA output and to set the maximum level measured in **LVT** logging mode.

MinRg / **MaxRg** menu items will only appear in the calibration menu with optional PZ12-LP non-contacting ultrasonic sensor.

MinRg - is distance from the optional PZ12-LP sensor to the highest water level (must be $\geq 8''/203$ mm). Use **↓** and **↑** to enter the minimum range.

MaxRg - is distance from the PZ12-LP sensor to the zero water level (must be $\leq 12'/3.66$ m).

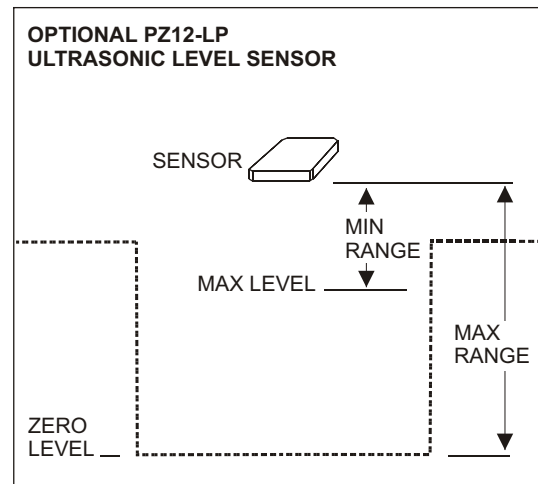

Press **↓** to **Damping**. Default setting is 2% to allow quick set-up of the instrument. 20% should be ideal for most applications. Increased damping (up to 99%) slows the AVFM-II's response to turbulence and will smooth the display and outputs under turbulent conditions. Decrease damping to minimize response time for fast level or velocity changes. Minimum setting is 0%.

Press **↓** to **Store?** and **→** to **Yes** to save your settings. Press **↓** or **↑** to **Relay Parameters**.

4-20mA OUTPUTS

4-20mA outputs transmit Flow, Level and Velocity. 4mA is fixed to zero flow, zero velocity and zero level. 20mA settings are individually configured in the **CALIBRATION** menu as described above.

MaxF entry sets 20mA Flow
MaxV entry sets 20mA Velocity
MaxLv1 entry sets 20mA Level

RELAY PARAMETERS

Each relay can be individually calibrated. Press \downarrow to R Function and \rightarrow to select: Off \rightarrow Pulse \rightarrow Flow \rightarrow Velocity \rightarrow Level.

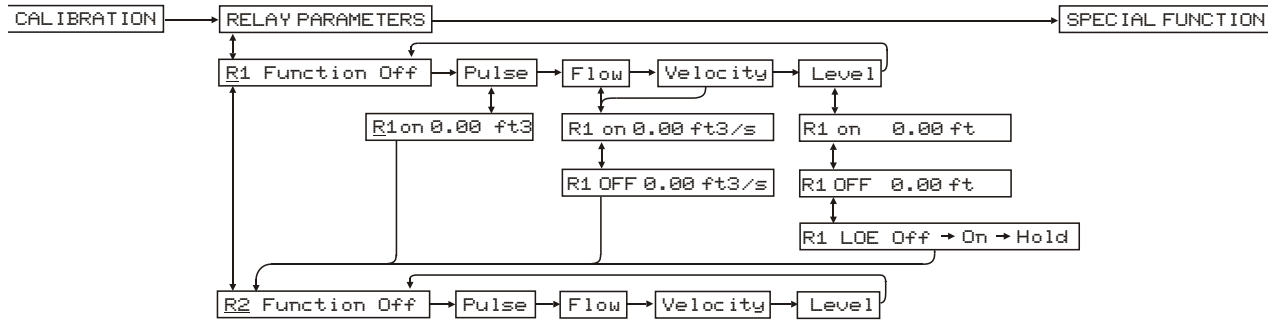

Off mode means the relay will not be energized

Pulse Press \downarrow and set digits to the flow volume increment required between relay pulses. Use this feature for remote samplers, chlorinators or totalizers. Maximum pulse setting is 999,999. Minimum time between pulses is 1 second and pulse duration is 350 milliseconds. Selection of **Level** mode disables this function.

Flow Press \downarrow to select flow mode for the relay, then **R1 on**. Use \downarrow and \uparrow to set the On flow rate to energize the relay.
R1 Off use \downarrow and \uparrow to set the Off set point. Selection of **Level** mode will disable this function.

Velocity Press \downarrow to select velocity mode for the relay, then **R1 on**. Use \downarrow and \uparrow to set the On flow velocity to energize the relay.
R1 Off use \downarrow and \uparrow to set the Off flow velocity. Selection of **Level** mode will disable this function.

Level Press \downarrow to select level mode for the relay, then **R1 on**. Use \downarrow and \uparrow to set the On level to energize the relay.
R1 Off Use \downarrow and \uparrow to set the Off level.

R1 LOE. Press \rightarrow to select **Off** \rightarrow **On** \rightarrow **Hold**. In a loss of echo condition the relay will turn off (de-energize), on (energize) or hold its current state. Each relay can be individually configured. Press \downarrow .

To calibrate a relay in level mode for echo loss only, set the relay On and Off points to exactly the same value, then set LOE to On mode. The relay will now energize only when a level echo loss condition occurs.

Press \downarrow to Store? Yes and \rightarrow to Yes. Press \uparrow or \downarrow to save your Relay settings.

SPECIAL FUNCTIONS

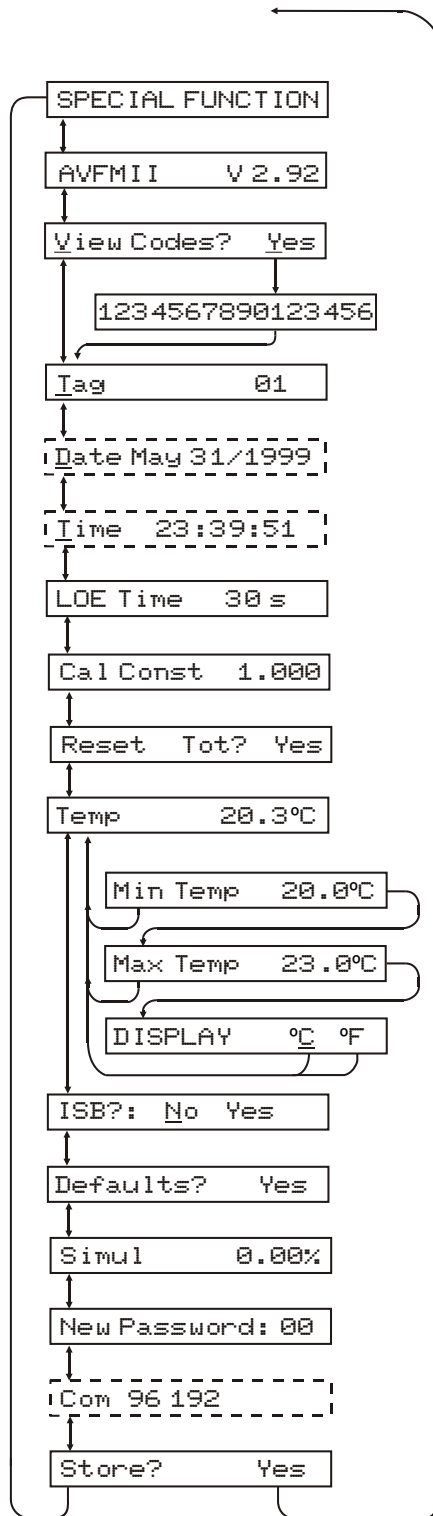

AVFM-II V2.92	shows software version installed
View Codes? Yes	Select <u>Y</u> es and then ↓ to display an instrument performance code. Faults detected by the instrument are stored in the code and will be requested by Greyline if you call for service or assistance.
Tag	Enter Instrument Tag number (0-9999)
Date JUN 01/2004	(with optional Data Logger) Press ➡ and ↑ or ↓ to change Month, Day Year.
Time HH:MM:SS	(with optional Data Logger) Press ➡ and ↑ or ↓ to change Hours, Minutes, Seconds
LOE TIME	Press ➡ and ↑ or ↓ to change the number of seconds without receiving level signal echo before the AVFM-II displays ECHO LOSS, and Control relays change state as calibrated under Relay Parameters. Factory default is 30 seconds and is recommended for most applications, Minimum is 10 seconds and maximum is 60 seconds.
Cal Const XXXX	Set to 1.000 for QZ02L transducer. (Note: Different transducer models require specific Cal. Constants.)
Reset Tot? Yes	(FLOW mode only) Position the cursor under <u>Y</u> es to reset the totalizer. Store this selection at the Store? <u>Y</u> es prompt.
Temp 25.0°C	Indicates current temperature at the sensor head. Press ➡ to Min Temp and ➡ to Max Temp to display the minimum and maximum temperatures the AVFM-II has sensed. Press ➡ to Display °C °F. Position the cursor under °C for celcius display or °F for Farenheight display. Press ↓ to return to Temp.
ISB?: No Yes	Select <u>Y</u> es only when the instrument is equipped with an optional Intrinsic Safety Barrier for sensor mounting in hazardous locations. This setting compensates for the electrical characteristics of an Intrinsic Safety Barrier.
Defaults? Yes	Press ➡ 3 times to select <u>Y</u> es. Store to erase <u>all</u> user settings and return instrument to factory default settings.
Simul	The Output simulation function controls all 4-20mA outputs, the digital display and control relays. Use it to simplify calibration of remote devices such as chart recorders or remote displays, and to test Relay set-points. Simulation digits are shown as a percentage of full scale. Use the ↑ and ↓ Arrow keys to simulate 0% (4mA), 100% (20mA), and increments of .05% (.008mA). Increments will automatically accelerate when the ↑ or ↓ is continuously pressed.
New Password	position cursor under digits and set new number between 00 and 99.
Com 96 192	Optional (with Data Logger) Speed of RS-232C transmission. Select 9600 or 19200 baud rate (must be set to match baud rate in 'Greyline Logger' software and any modems used for serial communication).

INSTALLATION - SENSOR LOCATION

1. Choose a sensor mounting location where silt or deposits are least likely to accumulate.
2. For best results flow should be evenly distributed across the channel and relatively free of turbulence. (The AVFM-II is very effective at averaging level and velocity readings in turbulent conditions, but best accuracy and response time is achieved with evenly distributed flow.)
3. Avoid vertical drops, obstructions or elbows immediately up and downstream from the sensor. Locate the QZ02L sensor at least 10 times maximum Head (level) and 10 times the channel width from these flow disturbances.

QZ02L VELOCITY-LEVEL SENSOR MOUNTING

Mount the QZ02L sensor with the stainless steel bracket and hardware supplied. Ensure that the sensor is parallel to the water surface (check with a level). Mount with the tapered end of the sensor pointing upstream and the sensor cable pointing downstream.

Clip or tie wrap the sensor cable securely to the pipe or channel wall.

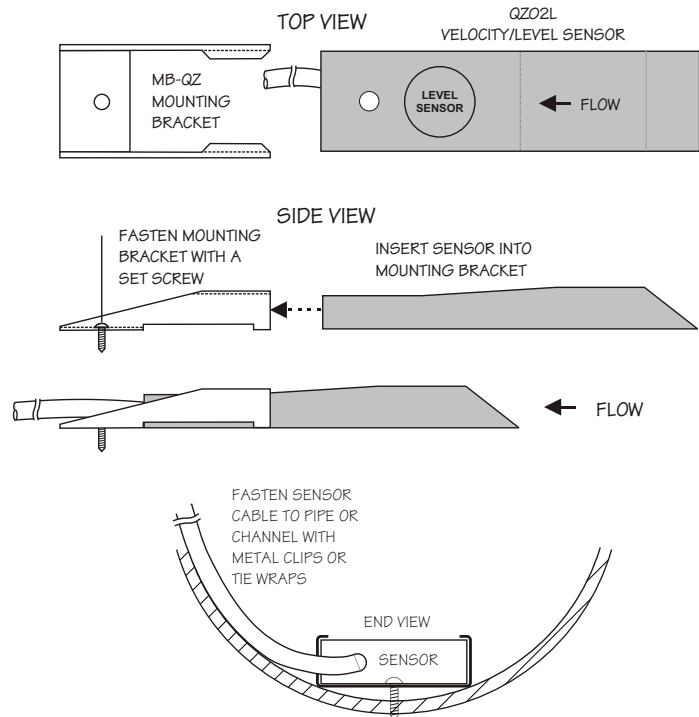

GOOD

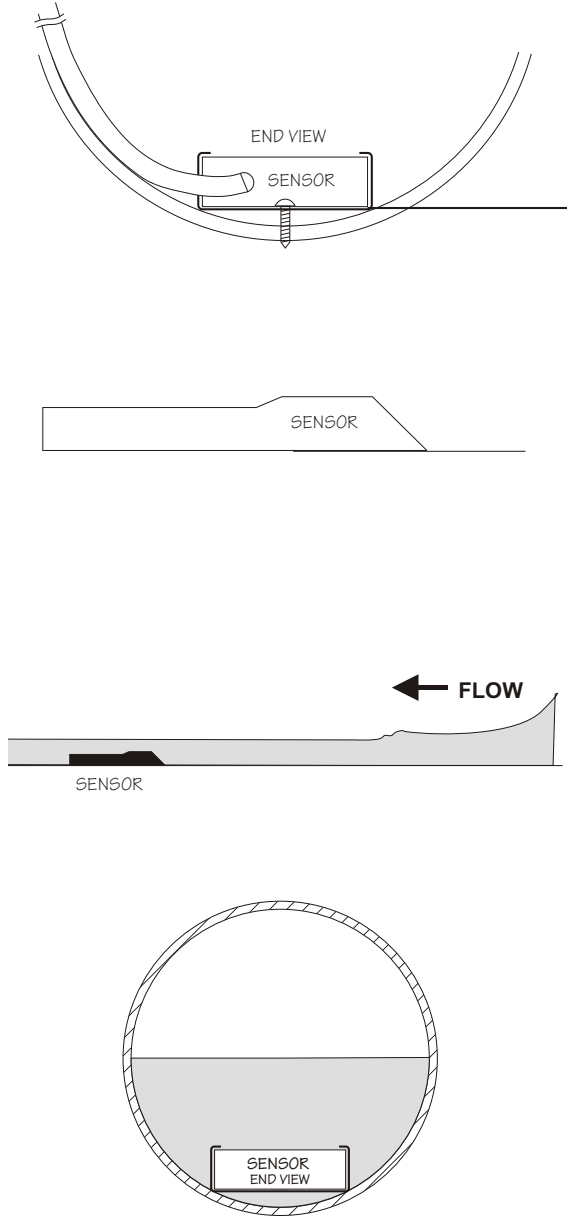

BAD

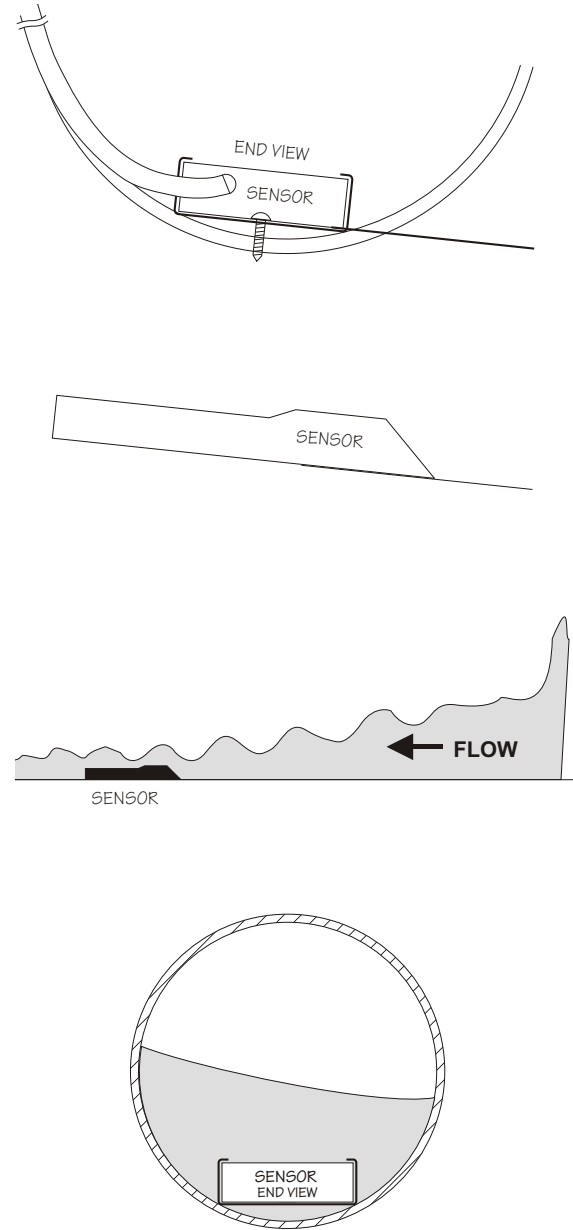

OPTIONAL PIPE BAND MOUNTING WITH QZ02L SENSOR

Install the stainless steel pipe band with the sensor mounting bracket at the invert (bottom) of the pipe. Ensure that the sensor bracket is parallel to the water surface (check with a level). Mount so the tapered end of the sensor will point upstream and the sensor cable will point downstream. (Turn the 1/4" hex nut clockwise to expand the bracket and secure to the pipe wall by friction fit.)

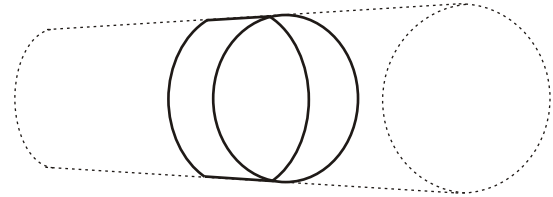

Insert the sensor into the mounting bracket and clip or tie wrap the sensor cable securely to the stainless steel pipe band as illustrated.

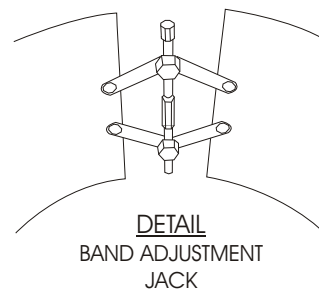
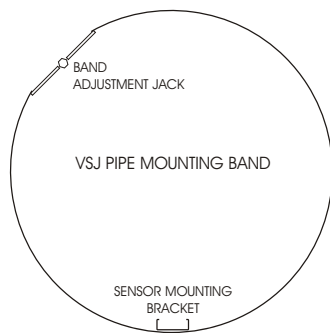

OPTIONAL QZ02L-DP VELOCITY SENSOR MOUNTING

Mount the velocity sensor at the bottom of the channel or pipe in a position where it will be continuously submerged. The QZ02L-DP velocity sensor does not have to be exactly parallel to the water surface. Position where silt or solids will not build-up on the sensor.

OPTIONAL PZ12-LP LEVEL SENSOR MOUNTING

Mount the PZ12-LP non-contacting ultrasonic level sensor in an unobstructed position at least 8" (203.2 mm) above the high water level. Install the stainless steel mounting bracket in a horizontal position (check with a level) and then insert the PZ12-LP sensor.

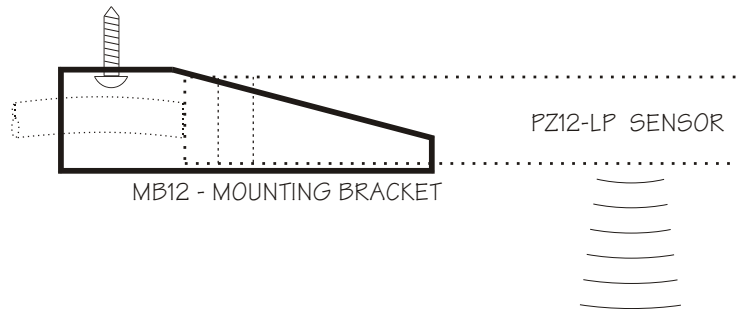

PZ12-LP MANHOLE MOUNTING

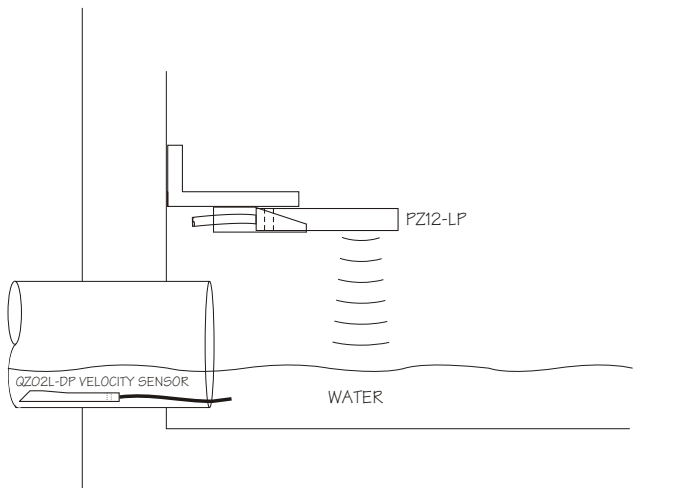

PZ12-LP PIPE MOUNTING

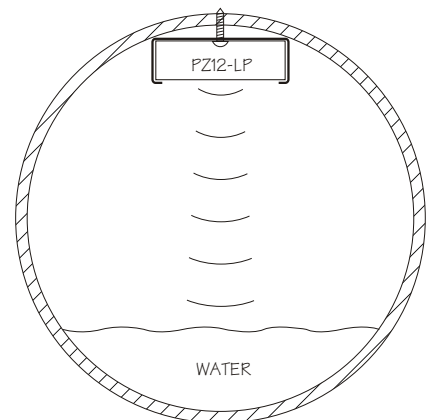

ENCLOSURE INSTALLATION

Locate the enclosure within 500 ft (150 m) of the sensor. It can be wall mounted with four mounting screws (supplied) or panel mounted with Option PM Panel Mounting Kit from Greyline Instruments. Avoid mounting the enclosure in direct sunlight to protect the electronics from damage due to overheating and condensate. In high humidity atmospheres, or where temperatures fall below freezing, Option TH Enclosure Heater and Thermostat is recommended. Seal conduit entries to prevent moisture from entering enclosure.

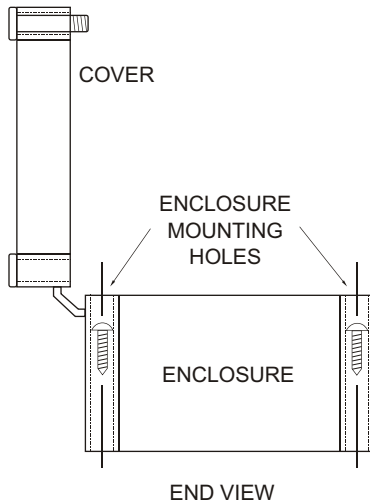

NEMA4X (IP66) WITH CLEAR COVER

1. Open hinged enclosure cover.
2. Insert #8 screws and washers through the four enclosure mounting holes to secure enclosure to wall or mounting stand.
3. Close cover.

Additional conduit holes can be cut in the end of the enclosure when required. Use a hole saw or Greenlee-type hole cutter to cut the required holes.

Note: This non-metallic enclosure does not automatically provide grounding between conduit connections. Grounding must be provided as part of the installation. Ground in accordance with the requirements of the National Electrical Code. System grounding is provided by connecting grounding wires from all conduit entries to the steel mounting plate or another point which provides continuity.

ERROR/WARNING MESSAGES

"ECHO LOSS"	No level echoes received within the LOE TIME setting. (See SPECIAL FUNCTION menu.) In Level mode the AVFM-II will hold the display and outputs at the last reading until a new echo is received. In FLOW mode it will display 0.00 and totalization will stop until an echo is received.
Er: ILLEGAL MinRg	With optional PZ12-LP level sensor only. The value entered for MinRg (Minimum Range) is less than 8" (20.3 cm). MinRg must be greater than or equal to 8" (20.3 cm)
Er: ILLEGAL UNITS	Your choice of UNITS exceeds a maximum value of 9,999,999. Use US MGD, Imp MGD or m3/d so that UNITS will be 9,999,999 or less.
Err: ILLEGAL SPAN	The value entered for MaxRg is the same or less than MinRg +2". Maximum range <u>must</u> be greater than minimum range.
- or - (on the large display)	Your choice of Units exceeds 9,999,999. Use USMG/d, IMG/d or m3/d so that Units will be 9,999,999 or less
ERR: ILLEGAL SETPOINTS	ON or OFF setpoint is < MinRg or > MaxRg
!! SENSOR OPEN !	Instrument has detected sensor connection/cable Open.
! SENSOR SHORTED !	Instrument has detected sensor connection/cable Shorted.

FIELD TROUBLESHOOTING

The AVFM-II uses an ultrasonic level sensor to determine channel AREA and an ultrasonic Doppler sensor to measure flow VELOCITY.

The QZ02L transducer combines both sensors in one housing.

An optional configuration uses the PZ12-LP “down-looking” level sensor and a QZ02L-DP velocity sensor.

To troubleshoot the AVFM-II, verify correct operation of LEVEL and VELOCITY measurements separately.

Note: Selecting “Defaults” in the SPECIAL FUNCTION menu will return the instrument to “as-shipped” factory settings.

LEVEL (QZ02L SENSOR)

<u>SYMPTOMS</u>	<u>FAULTS</u>	<u>SOLUTIONS</u>
EC bar graph at zero	- very turbulent flow - very aerated flow - sensor not level - sediment/dirt/grease build-up on sensor	- Increase LOE time (SPECIAL FUNCTION) - relocate sensor or use PZ12-LP - level sensor with “Bullseye” level - clean sensor
- Level display reads 1.0 inches	- Level less than 1.0 inches	

VELOCITY (QZ02L SENSOR)

<u>SYMPTOMS</u>	<u>FAULTS</u>	<u>SOLUTIONS</u>
- No velocity reading	- Grease/sediment on sensor - Improper hook-up	- Clean sensor with detergent - Check sensor connections

FUSE REPLACEMENT

1. Turn OFF power
2. Loosen 2 Phillips corner screws and remove power module from the chassis.
3. Locate fuse on Power Board
4. Replace fuse with 2 Amp/250V, 5 x 20mm fuse
5. Reinstall power module in the chassis.

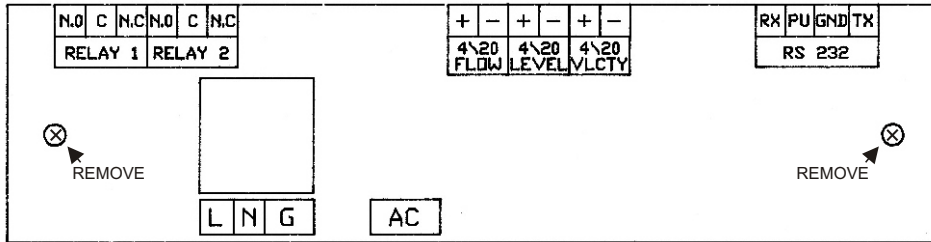

SENSOR CLEANING INSTRUCTIONS BEFORE HANDLING

AVFM-II sensors that have been immersed in sewage should be cleaned before handling.

1. Rinse sensor and cable to remove debris.
2. Immerse sensor and cable in a solution of 1 part household bleach (Javex, Clorox etc.) to 20 parts water for 5 minutes. Do not immerse open end of sensor cable or cable plug. Ensure that the protective cap is properly fitted to the cable plug before immersing in water or cleaning solution
3. Remove grease from sensor with clean water and mild soap. Do not use abrasive cleaners, solvents or high pressure washers.

SENSOR CLEANING WHILE AVFM-II IS IN OPERATION

Use a soft brush or broom to wipe the sensor face. DO NOT USE an abrasive tool or gouge the surfaces of the sensor.

Remove the sensor from its mounting bracket to remove severe build-up of debris or “stringers” attached to the sensor, cable or mounting bracket.

APPLICATIONS HOTLINE

For applications assistance, advice or information on any Greyline Instrument contact your Sales Representative, write to Greyline or phone the Applications Hotline below:

United States:	Tel: 315-788-9500	Fax: 315-764-0419
Canada:	Tel: 613-938-8956	Fax: 613-938-4857
Toll Free:	888-473-9546	
Email:	info@greyline.com	
Web Site:	http://www.greyline.com	

Greyline Instruments Inc.

Canada
16456 Sixsmith Drive
Long Sault, Ont. K0C 1P0

USA:
105 Water Street
Massena, NY 13662

PRODUCT RETURN PROCEDURE

Instruments may be returned to Greyline for service or warranty repair.

- 1** Obtain an RMA Number from Greyline -
Before shipping a product to the factory please contact Greyline by telephone, fax or email to obtain an RMA number (Returned Merchandise Authorization). This ensures fast service and correct billing or credit.

When you contact Greyline please have the following information available:

1. Model number / Software Version
2. Serial number
3. Date of Purchase
4. Reason for return (description of fault or modification required)
5. Your name, company name, address and phone number

- 2** Clean the Sensor/Product -

Important: unclean products will not be serviced and will be returned to the sender at their expense.

1. Rinse sensor and cable to remove debris.
2. If the sensor has been exposed to sewage, immerse both sensor and cable in a solution of 1 part household bleach (Javex, Clorox etc.) to 20 parts water for 5 minutes. Important: do not immerse open end of sensor cable.
3. Dry with paper towels and pack sensor and cable in a sealed plastic bag.
4. Wipe the outside of the enclosure to remove dirt or deposits.
5. Return to Greyline for service.

- 3** Ship to Greyline -

After obtaining an RMA number please ship the product to the appropriate address below:

*Canadian and International
Customers:*

Greyline Instruments Inc.
16456 Sixsmith Drive
Long Sault, Ont. K0C 1P0

RMA#

*USA
Customers:*

Greyline Instruments Inc.
204 150th Avenue
Madeira Beach, FL 33708

RMA#

LIMITED WARRANTY

Greyline Instruments warrants, to the original purchaser, its products to be free from defects in material and workmanship for a period of one year from date of invoice. Greyline will replace or repair, free of charge, any Greyline product if it has been proven to be defective within the warranty period. This warranty does not cover any expenses incurred in the removal and re-installation of the product.

If a product manufactured by Greyline should prove defective within the first year, return it freight prepaid to Greyline Instruments along with a copy of your invoice.

This warranty does not cover damages due to improper installation or handling, acts of nature, or unauthorized service. Modifications to or tampering with any part shall void this warranty. This warranty does not cover any equipment used in connection with the product or consequential damages due to a defect in the product.

All implied warranties are limited to the duration of this warranty. This is the complete warranty by Greyline and no other warranty is valid against Greyline. Some states do not allow limitations on how long an implied warranty lasts or limitation of incidental or consequential damages, so the above limitations or exclusions may not apply to you.

This warranty gives you specific legal rights, and you may also have other rights which vary from state to state.

Greyline Instruments Inc.

APPENDIX A - OPTIONS

**EXTRA SENSOR CABLE
(OPTION VXC)**

Each Greyline AVFM-II flow meter includes 25 ft. (7.6 m), 50 ft. (15 m) or 100 ft. (30 m) tri-coaxial sensor cable. This cable is shielded from electrical interference and is watertight with a polyurethane jacket. Additional cable and Cable Junction Box (Option VJB) may be ordered with the Flow Meter, or the cable may be spliced and extended up to 500 ft (152 m) total length as required during installation. No adjustment is required when the sensor cable is extended or shortened. Use only Greyline tri-coaxial VXC shielded cable, or run three RG174U coaxial cables in a metal conduit.

Extended sensor cable can be installed in conduit for mechanical protection. Recommended installation with a metal junction box is illustrated below:

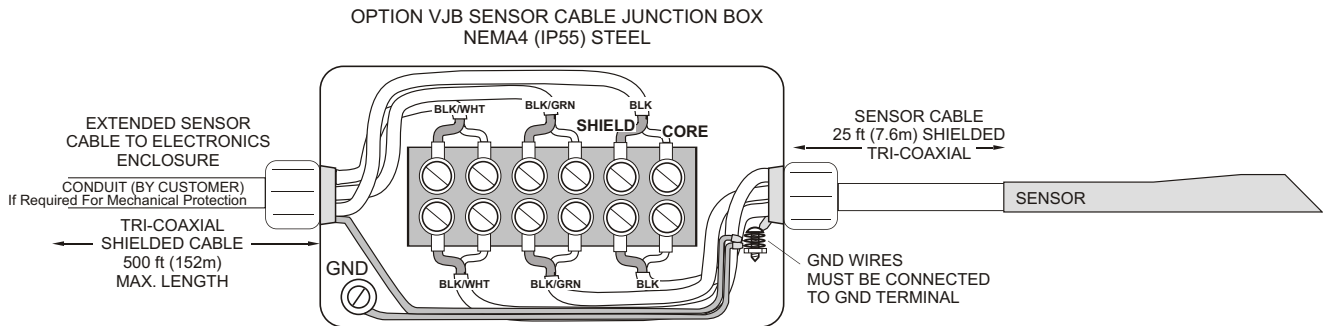

COAXIAL CABLE PREPARATION

VXC Doppler sensor cable can be cut and spliced up to a maximum length of 500 ft (152 m). Cable ends must be prepared as illustrated below.



**SENSOR CABLE JUNCTION BOX
(OPTION VJB)**

Optional Watertight steel NEMA4 (IP55) Junction Boxes with terminal strips are available from Greyline Instruments.

**DIMENSIONS
OPTION VJB - JUNCTION BOX**

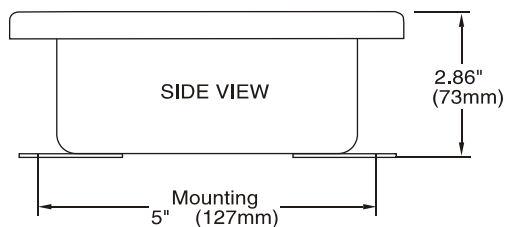
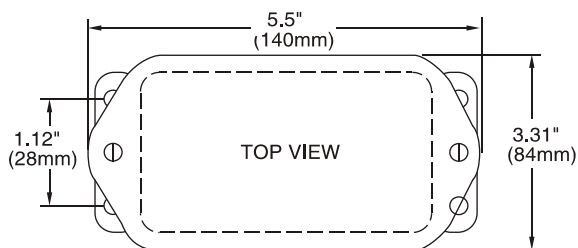

SS PIPE MOUNTING BAND - OPTION VSJ

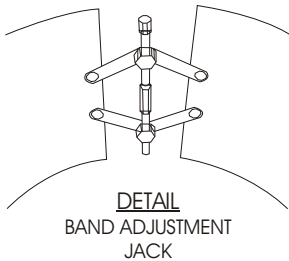

Use optional VSJ stainless steel Pipe Mounting Bands for easy Sensor installation in round pipes.

Each Pipe Band includes:

- Band Adjustment Jack allowing $\pm 0.5"$ (13 mm) adjustment from the nominal band size
- Stainless steel bracket for Sensor mounting
- Pre-drilled for tie wraps (included) to secure Sensor cable

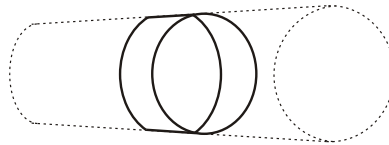
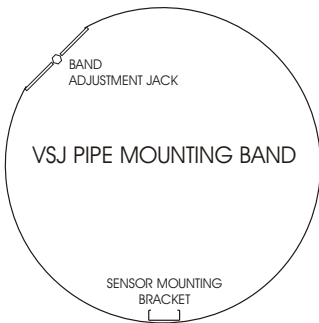

CODE BAND SIZE

CODE	BAND SIZE
VSJ6	6"/150 mm ID pipes
VSJ8	8"/200 mm ID pipes
VSJ10	10"/250 mm ID pipes
VSJ12	12"/300 mm ID pipes
VSJ14	14"/350 mm ID pipes
VSJ15	15"/375 mm ID pipes
VSJ16	16"/400 mm ID pipes
VSJ18	18"/450 mm ID pipes
VSJ20	20"/500 mm ID pipes
VSJ24	24"/600 mm ID pipes
VSJ30	30"/750 mm ID pipes

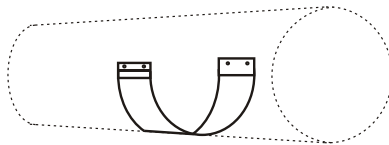
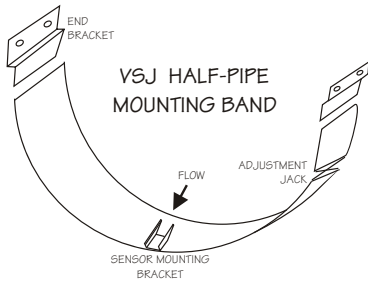

VSJ32-40	32-40" / 800-1000 mm ID pipes
VSJ42-54	42-54" / 1100-1375 mm ID pipes
VSJ56-72	56-72" / 1400-1800 mm ID pipes

Mounting Instructions:

Install the stainless steel pipe band with the sensor mounting bracket at the invert (bottom) of the pipe. Ensure that the sensor bracket is parallel to the water surface (check with a level). Mount so the tapered end of the sensor will point upstream and the sensor cable will point downstream. Turn the $\frac{1}{4}"$ hex nut clockwise to expand the bracket and secure to the pipe wall by friction fit.

Insert the sensor into the mounting bracket and clip or tie wrap the sensor cable securely to the stainless steel pipe band.

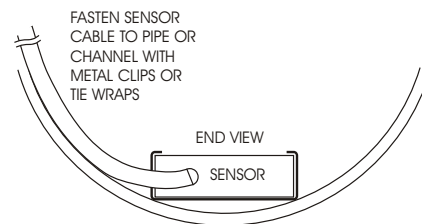

SENSOR INTRINSIC SAFETY - OPTION ISB

SENSOR MODELS QZ02L/QZ02L-DP/PZ12-LP (with built-in temperature compensation)

When connected through an Intrinsic Safety Barrier, the Greyline QZ02L, QZ02L-DP and PZ12-LP sensors are CSA certified for installation in a hazardous location rated:

- Class I, Groups C,D
- Class II, Groups E, F and G
- Class III

Intrinsic Safety Barriers may be ordered with the Greyline instrument and are supplied mounted in the Greyline instrument enclosure. Replacement barrier fuses (Part No. ISB-011239) may be purchased separately. Barriers must be installed in the sensor cable between the safe and hazardous locations, and must be mounted in either the safe or Div. 2 area. Barriers may be plate, busbar or rail mounted.

Intrinsic Safety Barrier Specifications: Certified, rated 9.3V max, 25 ohms min. (Recommended: Stahl Model 9001/02-093-390-10).

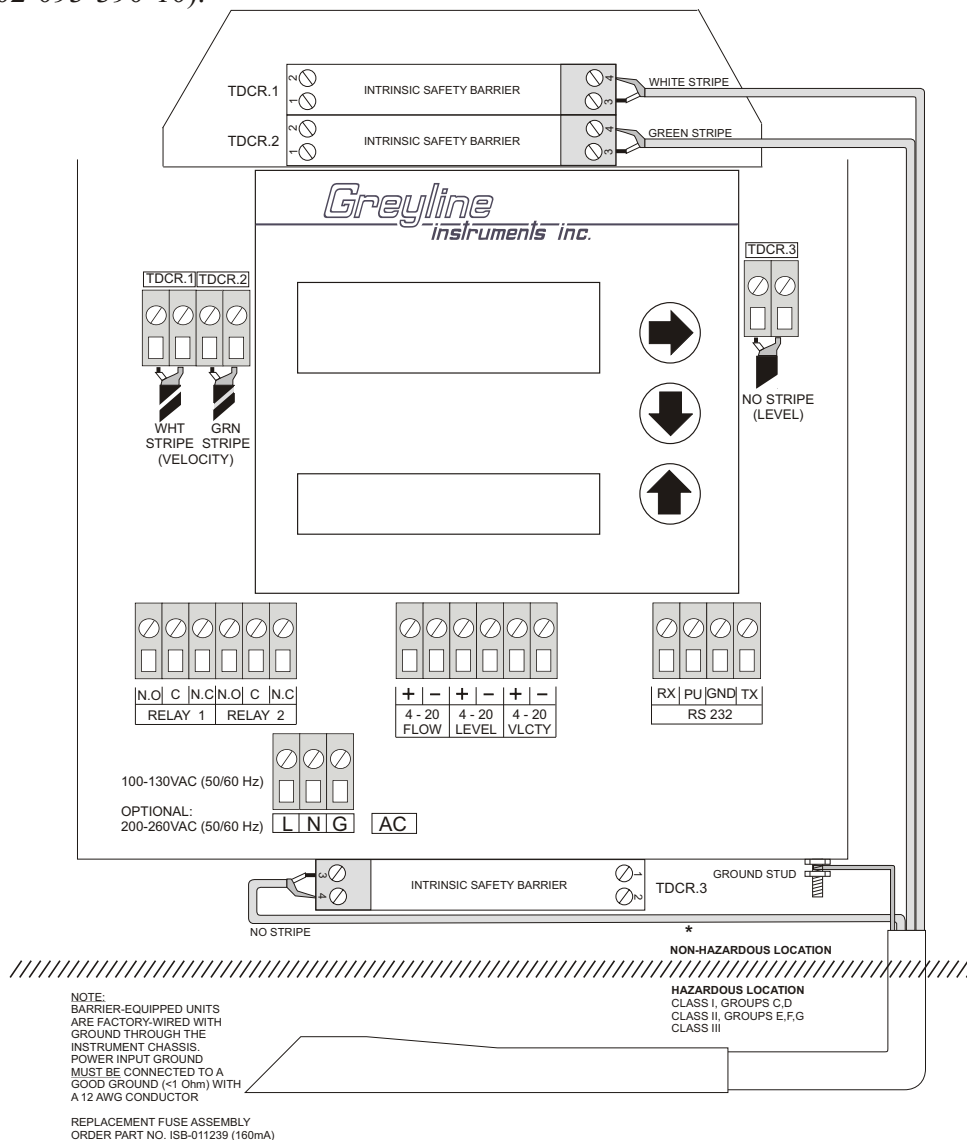

ENCLOSURE HEATER AND THERMOSTAT - Option TH

Instruments can be factory-equipped with an Enclosure Heater and Thermostat. The Thermostat is factory set to turn ON at 40°F (4.5°C) and OFF at 60°F (15.5°C). Power consumption is 15 Watts.

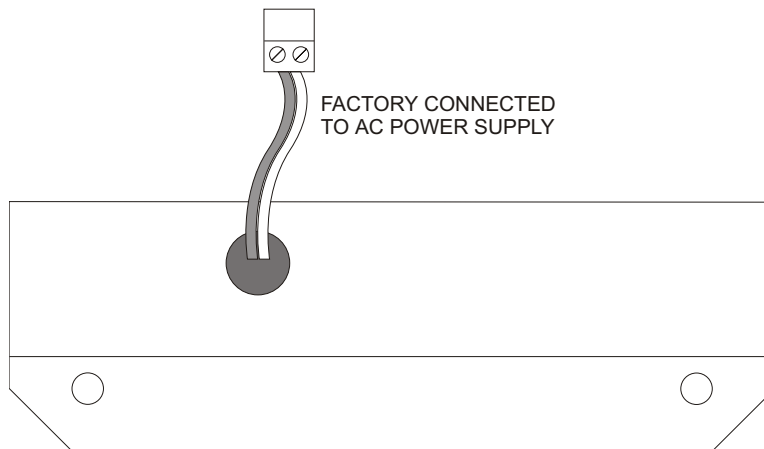

**POWER INPUT OPTION
9-36VDC**

AVFM-II Level & Flow Monitors may be ordered factory-configured for 9-36VDC power input.

FUNCTION TEST:

Connect the sensor to the **TDCR** terminals as shown below, then apply power.

- A. Place QZ02L sensor (flat to the bottom) in a bucket of water about 6” deep and select **Level** mode (from **UNITS/MODE** menu) to see a level reading.
- B. Select **Velocity** mode and stir the water to see a velocity reading.

CONNECTIONS:

POWER INPUT: Connect 9-36VDC/0.5 Amps to the + and - terminals. The Power Input GND must be connected to the nearest Ground pole. A 1 amp fuse in line is recommended. Maximum Power Consumption is 3.5 W continuous.

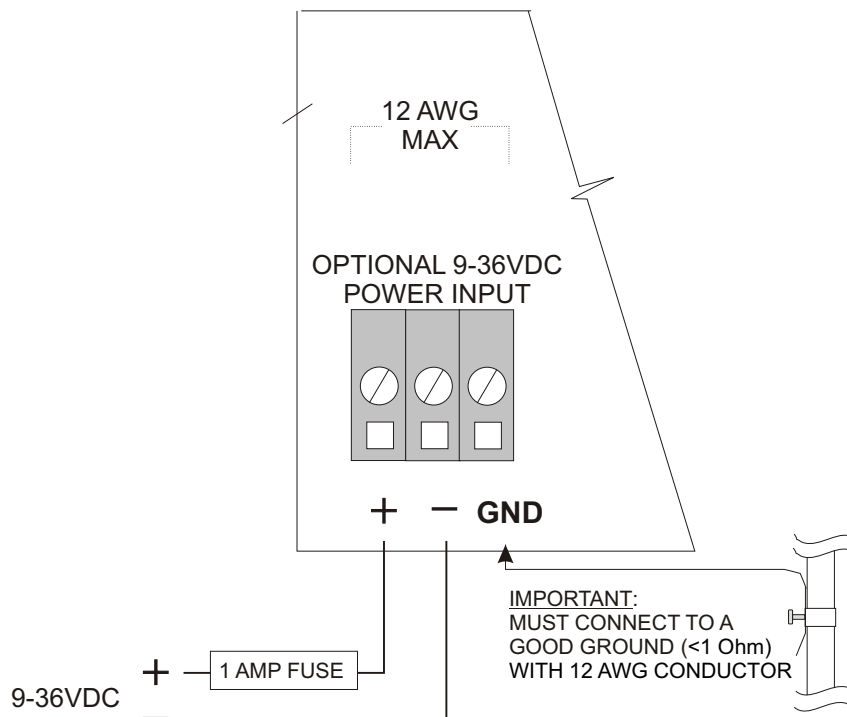

DATA LOGGER MENU (Optional)

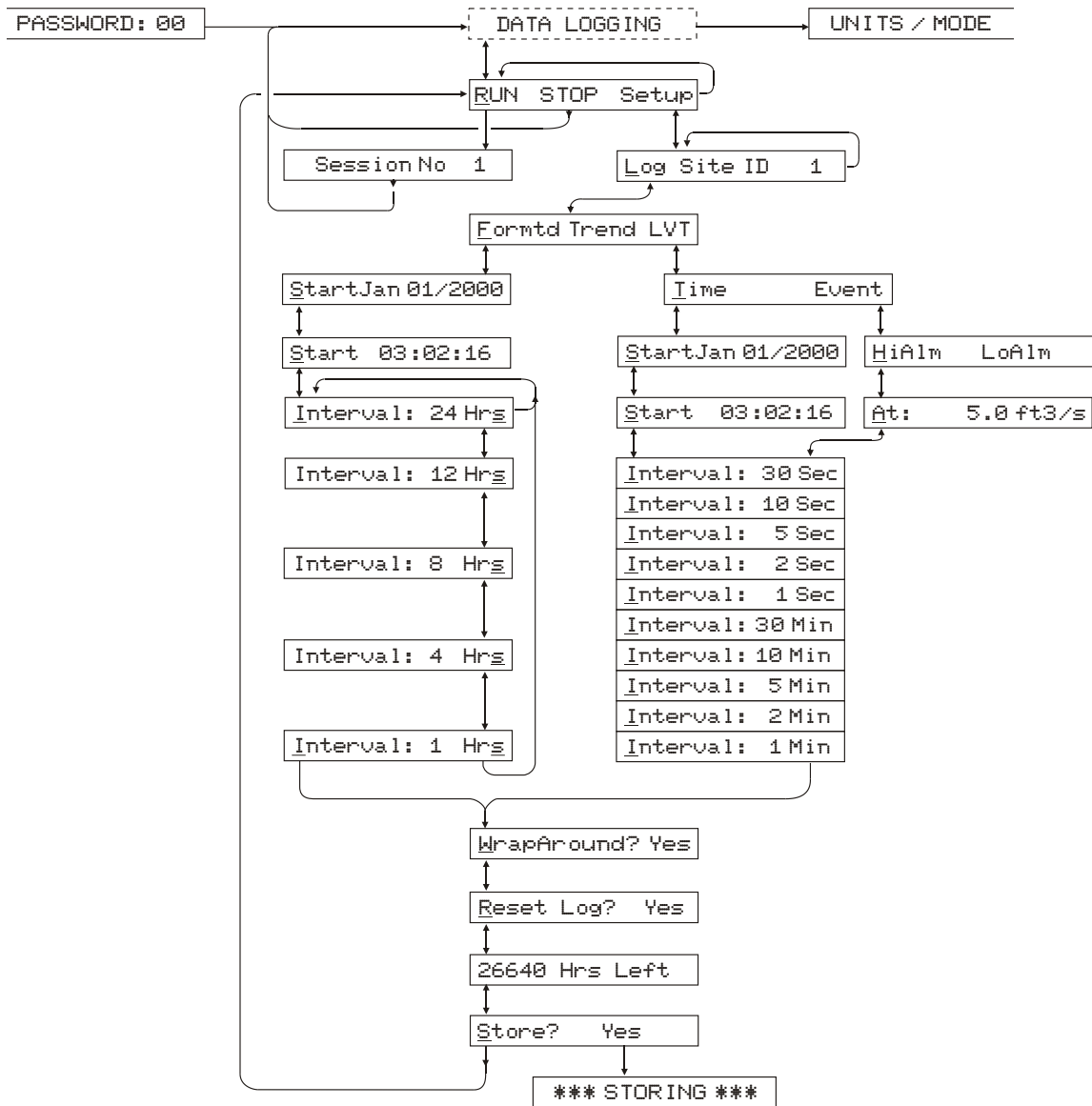

**DATA LOGGING (Optional)
Setup**

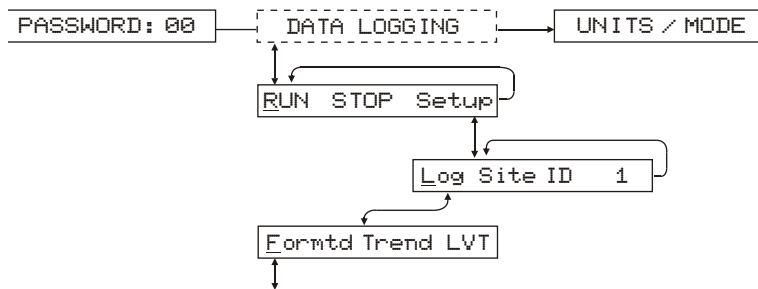

From RUN STOP SETUP press **➡** to SETUP and then **⬇** to Log Site ID 0. Press **➡** to position the cursor under the numeral and **⬇** or **⬆** to change the numerals. The “Site ID” number is retained with data logging sessions to identify logs stored from different locations.

Regardless of the logging mode selected a 24 hour flow report will be created and displayed under the 24 HR LOG menu

Formatted Data

Press **⬇** from Log Site ID and press **⬇** from Formtd.

“Formtd” data stores a summary of flow readings over a user-selectable time period. The summary includes:

- DATE and TIME
- Interval TOTAL
- Interval AVERAGE
- Interval MAX FLOW
- Interval MAX FLOW TIME
- Interval MIN FLOW
- Interval MIN FLOW TIME

From Formtd press **⬇** to Start MMM DD/YYYY (eg: Jan 01/2000). Press **➡** to position the cursor and then **⬇** or **⬆** to set the Month, Day and Year that logging will Start. Press **➡** to return to Start.

Press **⬇** to Start (time) and **➡** to position the cursor under the time column HH/MM/SS (24 hour clock in Hours/minutes/seconds, eg: 23:02:16) and then **⬇** or **⬆** to set the logging start Time. Press **➡** to return to Start .

Press **⬇** to Interval and **➡** to the Hrs column. Press **⬇** or **⬆** to select the flow logging interval. Choose from:

- 24 Hrs, or 12 Hrs, or 8 Hrs, or 4 Hrs, or 1 Hrs

Press **➡** to return to Interval. Press **⬇** and the AVFM-II will report **xxxxx Hrs Left** indicating the amount of logging time available with your current set-up. You can also press **⬆** to return to previous menu items and make changes.

Press **⬇** to WrapAround Yes?. Press **➡** to Yes? and **⬇** to enable the logging wrap function. In WrapAround mode the oldest data will be overwritten by the newest. If WrapAround is not enabled the logger will stop when its memory becomes full.

Press **⬇** to Reset Log? Yes. Press **➡** to Yes and then **⬇** to reset the Log and erase all previous sessions and stored values. Or press **⬇** from Reset Log? to retain existing data in the Log. The AVFM-II will display “xxxxx Hrs/Days Left.”

From the **xxxxx Hrs Left** display press **⬇** to Store? Yes. Press **➡** to Yes and then **⬇** to save your Data Logging setup, or press **⬇** from Store? to cancel changes made above and exit without storing changes.

From the Data Logging Store? Yes prompt the menu will return to RUN STOP SETUP. Press **➡** to position the cursor under RUN and press **⬇** to activate the Data Logger to start at your selected start Date and Time. The AVFM-II will display **SESSION NO. x**. Press **⬇** to return to DATA LOGGING.

Viewing FORMATTED Data Logs on the AVFM-II Display

24 Hour Formatted logs can be viewed directly on the AVFM-II display regardless of the logging mode selected. From RUN press **➡** to 24 HR LOG.

The 24 Hour Log Report is designed to be read one line at time using the **➡** key. Using the **⬇** or **⬆** keys will return the display to the Date column.

TODAYS DATE	DAILY TOTAL	DAILY AVERAGE	MAX FLOW	MAX FLOW TIME	MIN FLOW	MIN FLOW TIME
PREVIOUS DATE	"	"	"	"	"	"
PREVIOUS DATE	"	"	"	"	"	"
PREVIOUS DATE	"	"	"	"	"	"
PREVIOUS DATE	"	"	"	"	"	"
PREVIOUS DATE	"	"	"	"	"	"

The current day plus the past 255 days of data can be displayed. (Greyline Logger Windows software will display up to 1300 days of data.)

Trend Data Logging - Setup

From RUN STOP SETUP press **➡** to SETUP and then **⬇** to Log Site ID 0. Press **➡** to position the cursor under the numeral and **⬇** or **⬆** to change the numerals. The “Site ID” number is retained with data logging sessions to identify logs stored from different locations.

From Log Site ID press **⬇** to Formtd Trend LVT and press **➡** to position the cursor under Trend. Then press **⬇** to select Time based logging.

LVT Data Logging - Setup

Press ↓ from Log Site ID and press ↓ from LVT.

Level-Velocity-Temperature "LVT" mode stores separate level, velocity and temperature readings over a user - selectable time period. LVT data log files can be converted to flow using Greyline Logger software.

Note: In LVT mode three data points are stored for each time interval.

'Time' based Trend and LVT Logging

Time based logging allows you to choose Start and Stop times and a logging interval.

From Time press ↓ to Start MMM DD/YYYY (eg: Jan 01/2000). Press → to position the cursor and then ↓ or ↑ to set the Month, Day and Year that logging will Start. Press → to return to Start.

Press ↓ to Start (time) and → to position the cursor under the time column HH/MM/SS (24 hour clock in Hours/minutes/seconds, eg: 23:02:16) and then ↓ or ↑ to set the logging start Time. Press → to return to Start .

Press ↓ to Interval and → to the Sec/Min column. Press ↓ or ↑ to set the logging time interval. Choose:

30 Sec
10 Sec
5 Sec
2 Sec
1 Sec
30 Min
10 Min
5 Min
2 Min
1 Min

Press → to return to Interval and ↓ to Reset Log? To erase all existing data in the log press → to Yes and ↓. To keep existing data in the Log press ↓ from Reset Log? If you have made changes to the Start Date, Time or Interval, the data logger will automatically start a new "session". The AVFM-II will display "xxxxx Hrs/Days Left".

From the xxxxx Hrs Left display press ↓ to Store? Yes. Press → to Yes and then ↓ to save your Data Logging setup, or press ↓ from Store? to cancel changes made above and exit without storing changes.

From the Data Logging Store? Yes prompt the menu will return to RUN STOP SETUP. Press **➡** to position the cursor under RUN and press **⬇** to activate the Data Logger to start at your selected start Date and Time. The AVFM-II will display SESSION NO. x. Press **⬇** to return to DATA LOGGING.

‘Event’ based Trend and LVT Logging

Event based logging stores data points only when a High or Low set point has been reached.

With cursor under Event press **⬇** to HiAlm LoAlm. HiAlm will log points *above* a selectable level, flow or velocity point rate, while LoAlm will log points *below* a selectable level, flow or velocity point. Position the cursor under HiAlm or LoAlm and press **⬇** to the Att: prompt. Press **➡** to the numerals column and press **⬇** or **⬆** to set the alarm logging set point. Press **➡** to return to Att:

Press **⬇** to Interval and **➡** to the Sec/Min column. Press **⬇** or **⬆** to set the logging time interval.

Choose:

30 Sec
10 Sec
5 Sec
2 Sec
1 Sec
30 Min
10 Min
5 Min
2 Min
1 Min

Press **➡** to return to Interval and press **⬇** to WrapAround?. Press **➡** to Yes to overwrite the *oldest* data point with each new data point stored when the logger storage capacity has been reached.

To retain all data points collected and stop logging when the logger storage capacity has been reached press **⬇** from WrapAround?.

From Reset Log? press **➡** to erase all existing data in the log (including the on-screen 24 hr log) press **➡** to Yes and **⬇**. To keep existing data in the Log press **⬇** from Reset Log? If you have made changes to the Start Date, Time or Interval, the data logger will automatically start a new “session”. The AVFM-II will display “xxxxx Hrs/Days Left”.

From the xxxxx Hrs Left display press **⬇** to Store? Yes. Press **➡** to Yes and then **⬇** to save your Data Logging setup, or press **⬇** from Store? to cancel changes made above and exit without storing changes.

From the Data Logging Store? Yes prompt the menu will return to RUN STOP SETUP. Press **➡** to position the cursor under RUN and press **⬇** to activate the Data Logger to start. The AVFM-II will display SESSION NO. x. Press **⬇** to return to DATA LOGGING.

Note: Greyline Logger software cannot accurately calculate totals from 'event' based log files. Use 'trend' logging format if totals must be calculated.

Logging "Sessions"

Each time you select STOP in the DATA LOGGING menu, the Data Logger stores the current data in memory as a "SESSION NO" automatically numbered from "1" to "10". If you resume logging by selecting RUN, the Data Logger will report that a new logging session is started and titled "SESSION NO xx". When you download the logger files to your PC using Greyline Logger software, each Session will open as a separate graph/table titled "Greyline Data Log xx".

Important:

If you STORE instrument calibration changes under the UNITS/MODE or CALIBRATION menus, STOP the data logger and select RUN again to start a new logging Session with your new calibration values.

RS232C SERIAL OUTPUT (with optional Data Logger)

Format: 8 Bits, 1 Stop Bit, No Parity. (Baud rate may be changed under the SPECIAL FUNCTIONS menu. Factory default is 19200 baud).

Output Connector is DB9-Female. Use the cable supplied for connection to a PC Computer. Use the cable and optional Null Modem NM-DB9M/DB25M for connection to a modem.

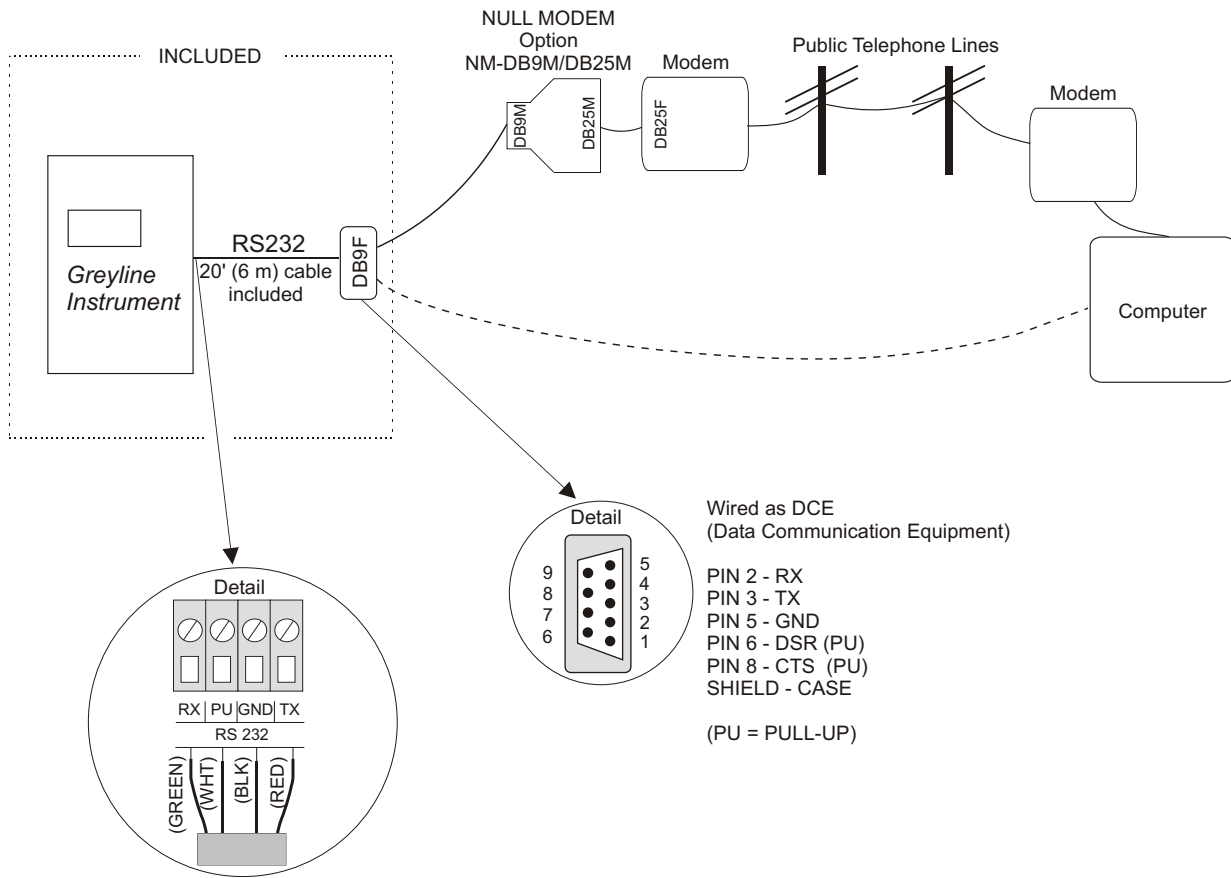

ENCLOSURE SUNSCREEN - OPTION SCR

Do not mount instrument electronics in direct sunlight. Overheating will reduce the life of electronic components and condensate may form during the heat/cool cycles and cause electrical shorts.

Note:

Exposure to direct sunlight can cause overheating and moisture condensation which will reduce the operating life of electronics.

Protect Instruments from direct sunlight with this iridite finished aluminum sun screen (Greyline Option SCR).

Seal conduit entries with caulking compound to further reduce moisture condensation.

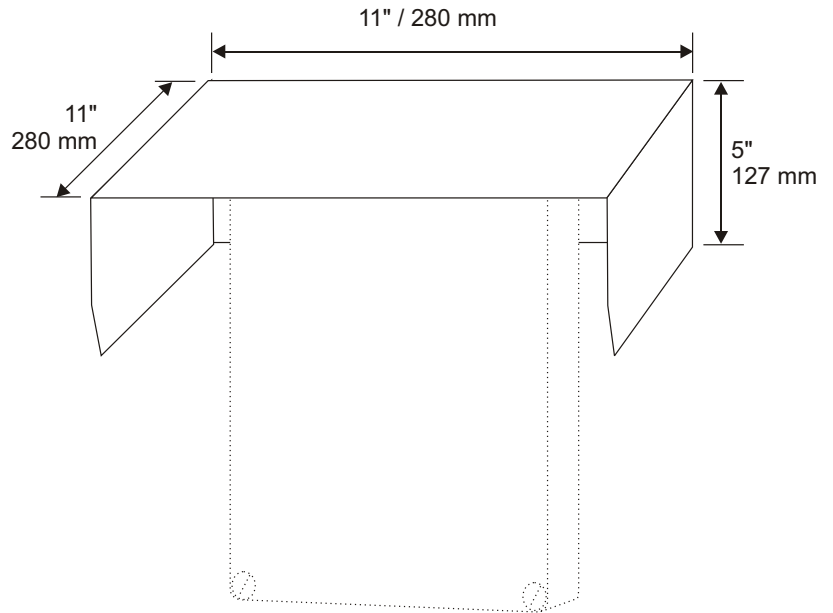

CONVERSION GUIDE		
FROM	TO	MULTIPLY BY
US GALLONS	CUBIC FEET	0.1337
US GALLONS	IMPERIAL GALS	0.8327
US GALLONS	LITRES	3.785
US GALLONS	CUBIC METERS	0.003785
LITRES/SEC	GPM	15.85
LITRES	CUBIC METERS	0.001
BARRELS	US GALLONS	42
BARRELS	IMPERIAL GALS	34.9726
BARRELS	LITRES	158.9886
INCHES	MM	25.4
DEGREES F	DEGREES C	(°F-32) x 0.556
POUNDS	KILOGRAMS	0.453
PSI	BAR	0.0676
FOOT ²	METER ²	0.0929

VOLUME CALCULATION FOR ROUND TANKS: $3.142 \times R^2 \times H$

R = TANK RADIUS (½ TANK DIAMETER)

H = TANK HEIGHT

SPECIFICATIONS

- Electronics Enclosure:** NEMA4X (IP 66), watertight and dust tight, fiberglass with clear, shatterproof hinged Lexan cover
- Accuracy:** Level: $\pm 0.25\%$ of Range
Velocity: $\pm 2\%$ of Reading
Repeatability: 0.1% F.S.,
Linearity: 0.1%F.S.
- Display:** Flow/Level Values: $\frac{3}{4}$ " / 19 mm high, 4 digit LCD
Menu/Status/Totalizer: 16 digit LCD alphanumeric
- Programming:** 3-button keypad with Menu selection. Calibration parameters are permanent when Stored (even through power interruptions)
- Power Input:** 100-130VAC, 50/60 Hz, (6.2 W max.)
Optional: 200-250VAC, 50/60 Hz, (6.2 W max.)
Optional: 9-36VDC (3.3 W max.)
- Output:** 3 Isolated 4-20mA, 1000 ohm load maximum
- Control Relay:** Qty 2, rated 5 ampere SPDT
- Temperature Compensation:** Automatic, temperature probe built in to level Sensor
- Electrical Surge Protection:** Sensor, 4-20mA, AC power input
- Operating Temperature:** -5 to 140°F (-20 to 60°C). Optional Enclosure Heater recommended for (electronics) condensation protection below 32°F (-1°C)

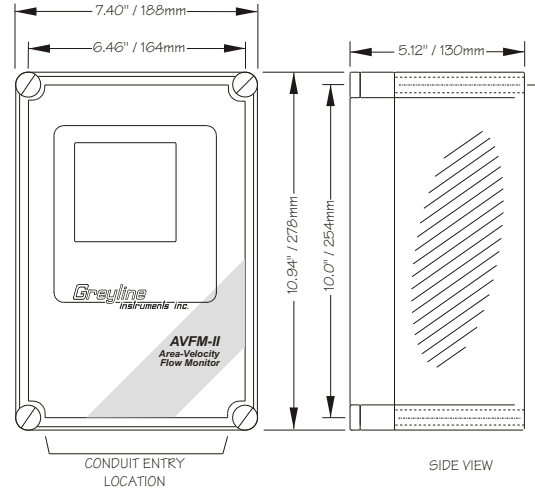

Velocity/Level Sensor QZ02L

- Minimum Velocity:** 0.1 ft/sec (0.03 m/sec)
- Maximum Velocity:** 20 ft/sec (6.2 m/sec)
- Minimum Head:** 1 in. (25.4 mm)
- Maximum Head:** 15 ft. (4.57 m)
- Operating Temperature:** 5 to 150°F (-15 TO 65°C)
- Exposed Materials:** PVC, epoxy resin, polyurethane, ultem
- Sensor Cable:** 25 ft. (7.6 m) submersible polyurethane jacket, shielded, 3 coaxial
- Hazardous Rating:** CSA rated Intrinsically Safe Class I, Groups C,D, Class II, Groups E,F,G with optional Intrinsic Safety Barrier

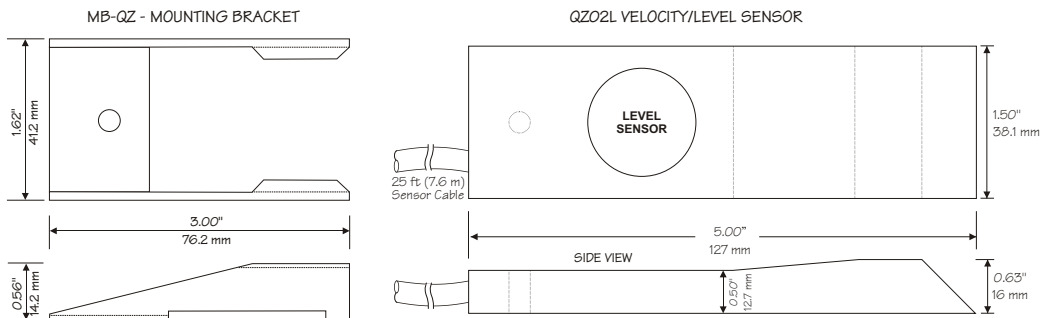

Optional (Velocity only) Sensor QZ02L-DP

- Minimum Velocity:** 0.1 ft/sec (0.03 m/sec)
- Maximum Velocity:** 20 ft/sec (12.2 m/sec)
- Operating Temperature:** 5 to 150°F (-15 to 65°C)
- Exposed Materials:** PVC, epoxy resin, polyurethane, ultem
- Sensor Cable:** 25 ft (7.6 m) submersible polyurethane jacket, shielded, 3-coaxial
- Hazardous Rating:** CSA rated Intrinsically Safe Class I, Groups C,D, Class II, Groups E,F,G, with optional Intrinsic Safety Barrier

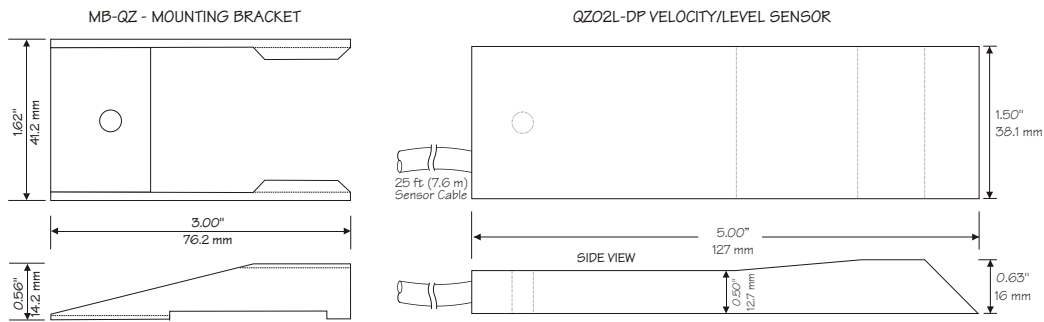

Optional Sensor PZ12-LP

- Maximum Range:** 12 ft (3.66 m)
- Minimum Range:** 8" (203.2 mm)
- Beam Angle:** 8°
- Operating Temperature:** -40 to 150°F (-40 to 65°C)
- Exposed Materials:** Sensor - PVC, Mounting Bracket - 316 Stainless
- Hazardous Rating:** CSA rated Intrinsically Safe Class I, Groups C,D, Class II, Groups E,F,G with optional Intrinsic Safety Barrier

