

SENSOR MOUNTING

Ultrasonic Sensor Model PZ34

General Specifications

- Maximum Range: 32 ft. (10 m)
- Minimum Range (Deadband): 16" (406.4 mm)
- Operating Frequency: 46 KHz
- Beam Angle: 8°
- Temperature Compensation: Automatic, continuous
- Operating Temperature: -40° to 150° F (-40° to 65° C)
- Maximum Operating Pressure: 20 psi (1.35 bar)
- Exposed Materials: PVC
- Sensor Mounting: 3/4" NPT
- Maximum Cable Length: 500 ft (150 m)
- Optional Hazardous Rating: CSA rated Intrinsically Safe Class I, Groups C,D, Class II, Groups E,F,G with optional Intrinsic Safety Barrier. Note: Max Range reduced to 25 ft. (7.8 m) with ISB option.

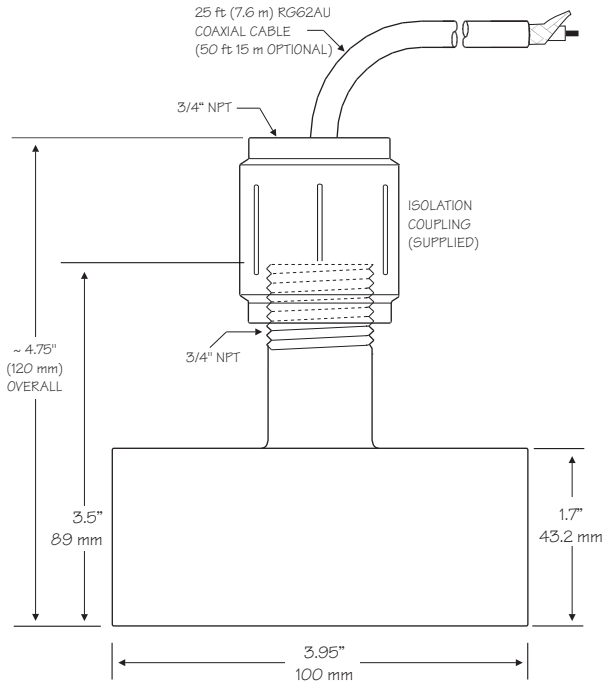

Notes:

1. Shield from direct sunlight (temperature probe in sensor)
2. Use the "Isolation Coupling" supplied for mounting.
3. Use with Option ISB Intrinsic Safety Barrier for installation in hazardous locations.
4. Run Sensor cable in grounded metal conduit with no other conductors.
5. Extend Sensor cable up to 500 ft (150 m) with RG62AU coaxial only.
6. Refer to the Instruction Manual for complete installation and wiring instructions.

Recommended Sensor Mounting

