

USER'S GUIDE

Installation & Operation
Instructions

Level & Flow Monitor
Model SLT32
Manual Series B.12.1

Note: This page has been left blank intentionally.

INDEX

| | |
|---|----|
| BenchTest | 4 |
| Connections | 4 |
| Keypad System | 5 |
| Menu - Flow Chart | 5 |
| Run | 7 |
| Totalizer | 7 |
| Password | 7 |
| Units / Mode | 8 |
| Flume Selection | 10 |
| Calibration - for Level | 11 |
| Calibration- for Open Channel Flow | 11 |
| 4-20mA Current Loop Offset | 13 |
| Rejection Time | 13 |
| Relay Parameters | 14 |
| Special Functions | 16 |
| Sensor Mounting/Location - Tank Level | 18 |
| Sensor Mounting Methods | 20 |
| Sensor Mounting/Location - Open Channel Flow | 21 |
| Enclosure Installation | 24 |
| Error/Warning Messages | 25 |
| Field Troubleshooting | 26 |
| Installation Considerations In Noisy Environments | 29 |
| Applications Hotline | 32 |
| Product Return Procedure | 33 |
| Warranty | 34 |
| Appendix A - Options | 35 |
| Data Logger | 39 |
| RS232C Serial Output | 44 |
| Appendix B - Applications Background | 47 |
| Conversion Guide | 48 |
| Specifications | 49 |
| Calibration Worksheet - Level | 53 |
| Calibration Worksheet - Flow | 54 |

IMPORTANT NOTE: This instrument is manufactured and calibrated to meet product specifications. Please read this manual carefully before installation and operation. Any unauthorized repairs or modifications may result in a suspension of the warranty.

Available in English

Available in Adobe Acrobat pdf format

Disponible en français

Disponible en español

QUICK BENCH TEST:

Connect Sensor to the **T.DUCER** terminals as shown below, then apply Power. When properly connected figures will show on the large LCD display. Test operation of the SLT32 by holding the sensor steadily and aiming at a flat, stable target 12 to 28" (305 to 711 mm) away from the end of the sensor. Allow a few seconds for the SLT32 to lock onto the target before displaying its distance. The SLT32 will now display distance in ft or cm (factory calibration).

NOTE: The SLT32 will not detect targets beyond user entered MaxRg.

CONNECTIONS: POWER INPUT:

The standard model requires AC power input between 100-130VAC 50/60Hz (2 amp fuse is recommended). No adjustments are necessary for any voltage in this range. Optional 230VAC requires power input between 200-260VAC 50/60Hz. (See OPTIONS section of this manual for connection of optional 9-36VDC power input).

IMPORTANT NOTE: To comply with CSA/NRTL standards, AC power input and relay connection wires must have conduit entry to the instrument enclosure.

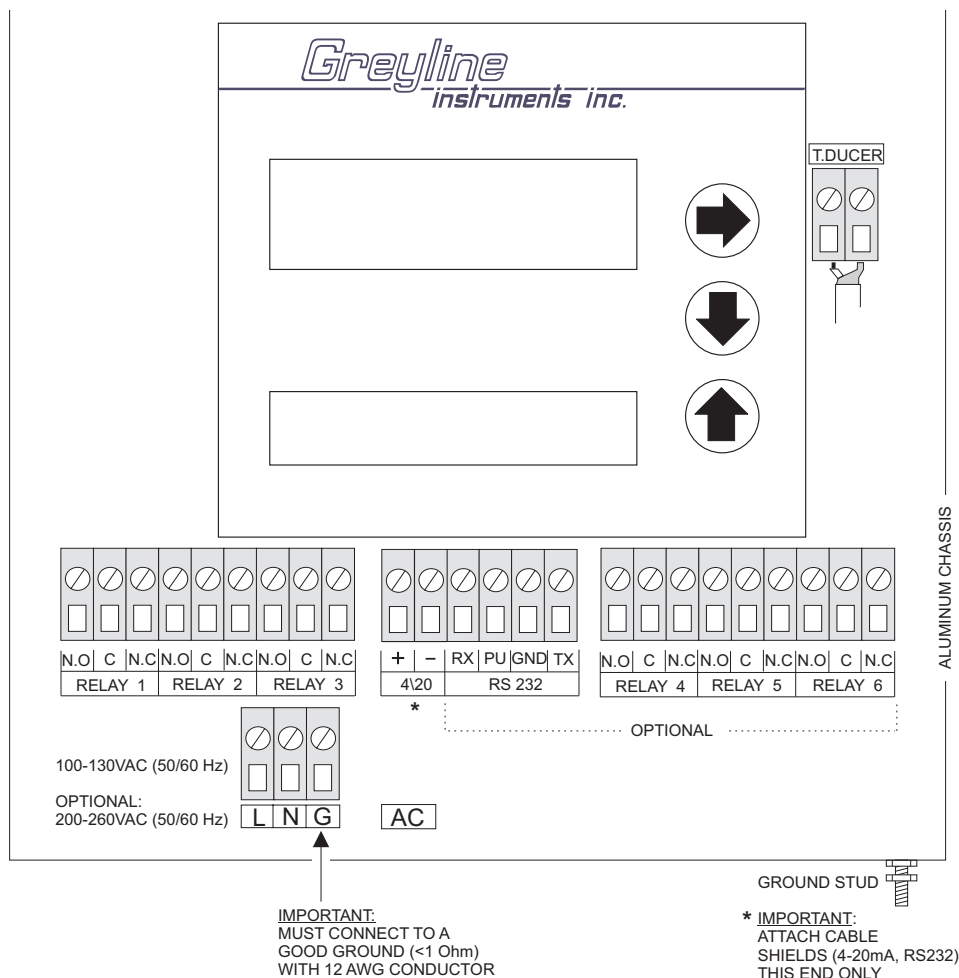

KEYPAD SYSTEM

The SLT32 has a simple 3-button calibration system. Operating and calibration modes are shown on the 16-digit alphanumeric display. The keypad is used to move around the menu to calibrate the SLT32, and to view operating mode and functions. A beep is sounded as each key is pressed. If the keypad is not used for 2 minutes, the SLT32 will automatically go to RUN mode (scrolling display). Use the keypad to explore the Menu and become familiar with its features.

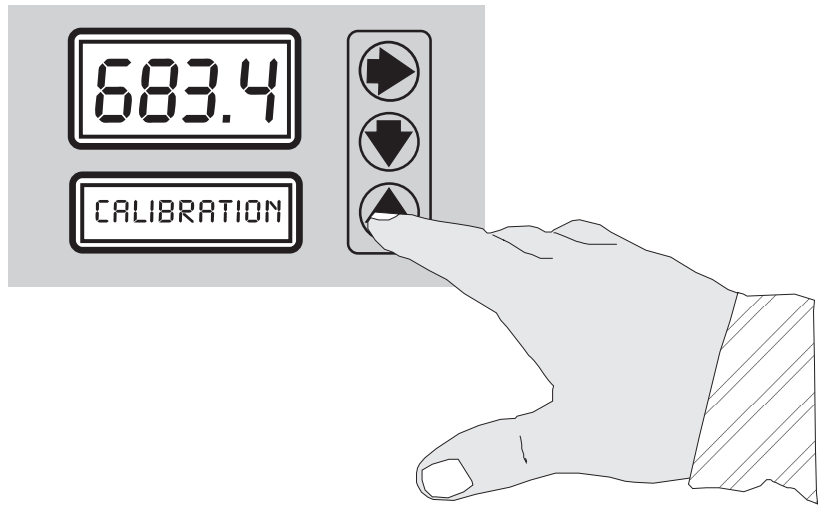

MENU - FLOW CHART

The following diagram shows part of the SLT32 Menu system. Arrows show the three directions to leave a box. Pressing a corresponding keypad arrow will move to the next box in the direction shown. Move the cursor (or underline) under numerals to increase or decrease the number with the **↑** **↓** keys.

At the bottom of each Menu column is a Store? Yes box. To store the calibration values permanently (even through power failure), move the cursor under Yes and press the **↓** or **↑** key. If the **↓** key is pressed with the cursor under Store? no changes will be stored and the system will return to the top of the Menu column.

SLT32 - CALIBRATION MENU

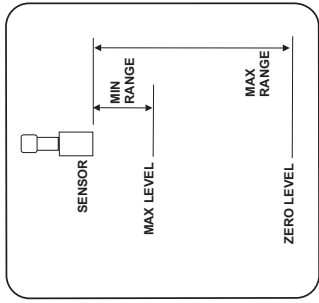
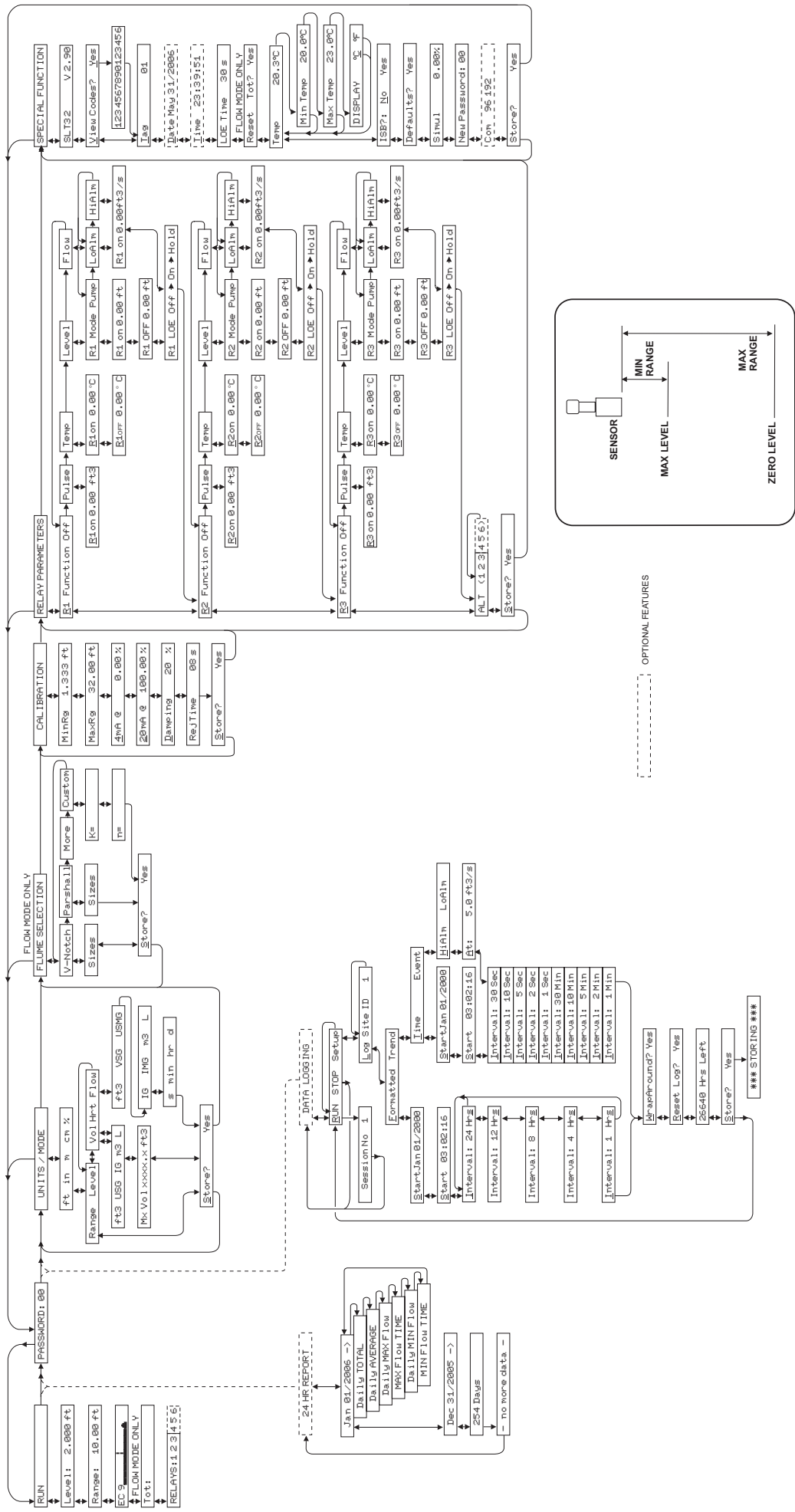

OPTIONAL FEATURES

STORING

RUN

A scrolling display shows the units selected from the UNITS/MODE column, the mode of operation (Range, Level or Flow), the full scale value for the large numeric display, Totalizer value (in FLOW mode), and air temperature at the sensor location.

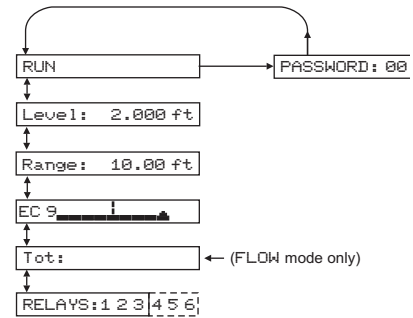

LEVEL READING

From RUN use ↓ to view the level measured by the instrument.

RANGE READING

From RUN use ↓ to view the range measured by the instrument. (Range is distance from the bottom of the sensor to the water surface.)

ECHO CONFIDENCE

Echo Strength is automatically adjusted by the SLT32 in response to operating conditions in the applications.

From RUN use ↓ to get to the Echo Confidence display, EC.

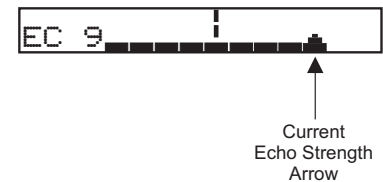

TOTALIZER

The Totalizer display will only be enabled when the SLT32 is calibrated in FLOW mode. From RUN use ↓ or ↑ keys to display Tot: value. The Totalizer value is updated every 2 seconds with flow volume 1 litre (0.264 USG). The display will show up to 10 digits and then restart at 0 automatically.

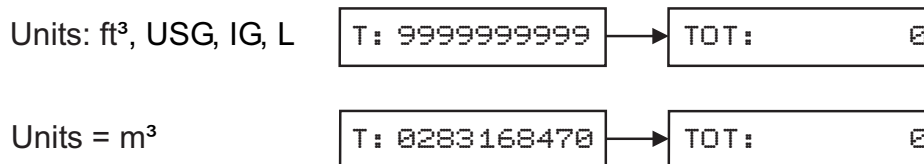

Press ↓ or ↑ keys to return to RUN.

The totalizer can be reset to zero by going → to SPECIAL FUNCTION and ↓ to Reset Tot?.

RELAY STATUS DISPLAY

Press ↓ from Tot: to RELAYS 1,2,3.

Energized relays will be displayed in reverse type RELAYS: 1 2 3

PASSWORD

The password (a number from 00 to 99) prevents unauthorized access to the CALIBRATION menu.

From RUN (scrolling display) press \rightarrow to PASSWORD.

Press \rightarrow to place the cursor under the digits and \downarrow or \uparrow to change the number and then \rightarrow to proceed to CALIBRATION.

Factory default Password is 00. A new password can be stored by going \rightarrow to SPECIAL FUNCTION and \downarrow to New Password.

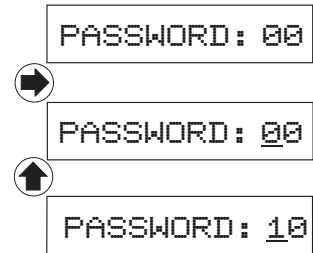

UNITS / MODE

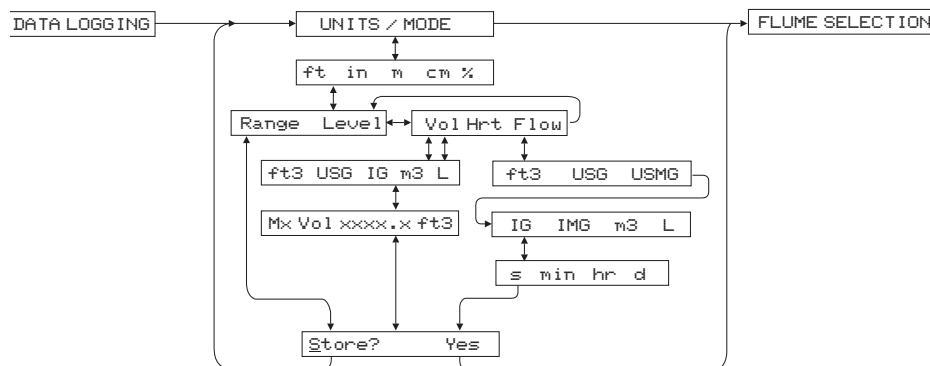

Press \rightarrow to UNITS/MODE, then \downarrow . Press \rightarrow to move the cursor under the required measurement units:

| | | |
|----|---|-------------|
| ft | - | feet |
| in | - | inches |
| m | - | meters |
| cm | - | centimeters |
| % | - | percent |

Press \downarrow to Range Level Vol Hrt Flow. Use \rightarrow to select the operating mode of the SLT32.

- Range mode displays distance from the sensor to the target or liquid surface like a tape measure. Range mode is useful to measure the exact distance from the sensor to the zero level during calibration, or to monitor "outage" or free space in a tank.
- Level mode can be used to measure tank level in linear units, or "Head" (height of flow) in an open channel for comparison with a flume manufacturer's flow tables.
- Vol Volume mode displays tank inventory in engineering units like gallons or liters.
- Hrt Horizontal Round Tank mode sets the SLT32 to calculate and display volume units in a horizontal round tank.
- Flow mode is for open channel flow through a flume or weir.

From Vol Hrt or Flow press → to make your selection. (Range or Level mode will bypass the Volume units selection menu). Vol Hrt or Flow modes will give you the additional choice of volumetric units:

- ft³ - cubic feet
- USG - US gallons
- USMG - US million gallons (FLOW only)
- IG - Imperial gallons
- IMG - Imperial million gallons (FLOW only)
- m³ - cubic meters
- L - liters

Press → to position the cursor underneath your selection and press ↓ to make your selection.

Vol or Hrt modes will also prompt you to enter a maximum volume. Press ↓ from M×Vol to position the cursor under the first digit. Use ↓ or ↑ to change the digits or decimal point to enter the actual maximum volume you will be measuring. Press → to return to M×Vol and ↓.

You can enter values up to 6 digits (e.g. 150,000 liters). When the measured tank volume exceeds 4 digits, the SLT32 will automatically display a ‘multiplier’ on the lower alphanumeric display.

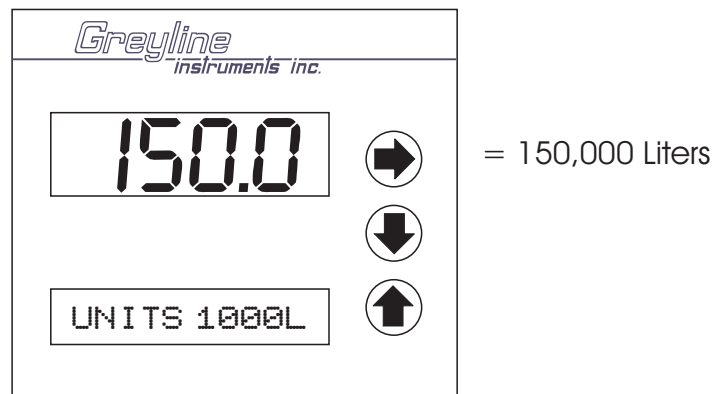

FLOW mode will offer the additional selection of time units:

- s - seconds
- min - minutes
- hr - hours
- d - day

Note: The SLT32 will display Er: ILLEGAL UNITS if your choice of Units exceeds a maximum value of 9,999,999. Use US MGD, Imp MGD or m³/d so that Units will be 9,999,999 or less. Press ↓ to Store and → to Yes. Then press ↓ or ↑ to store all your UNITS/MODE selections.

FLUME SELECTION

The FLUME SELECTION menu will only appear in FLOW mode.
Use **↓** and **→** to select the correct Flume or Weir.

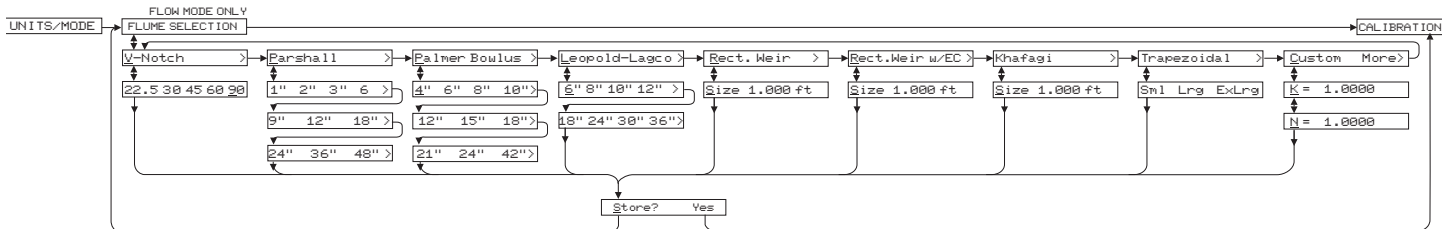

Use **↓** and **→** again to select the Size then **↓** to Store? and **→** to Yes.
Press **↓** or **↑** to store flume selection and get to CALIBRATION mode.

TRAPEZOIDAL: This menu selection supports 60° trapezoidal flumes only.

CUSTOM FLUMES: Experimental or empirical data for any flume or weir can be reduced to an equation of the form $Q = K H^n$ where:

- Q** is flow volume
- K** is as scaling factor which includes flume size and units of flow measurement
- n** describes the flume non-linearity
- H** is the level being measured

Use the Greyline Utility program **FIND K&n.exe** to determine **K** and **n** constants from entered data. Select CUSTOM for flumes or weirs not listed in the Menu. At the **K** : prompt enter a 'K' constant. At the **n** : enter an 'n' constant.

CALIBRATION

- for Level/Inventory Applications

1. Before starting the calibration determine:

- a) MAX RANGE = _____
(Maximum range = distance from Sensor to Zero level)
- b) MAX LEVEL = _____
(Maximum level of product being measured)
- c) MIN RANGE = _____
(Distance from sensor to Max Level)
Minimum range = MAX RANGE - MAX LEVEL
(must be at least 8" / 203 mm depending on sensor model)

2. Check the maximum range with the sensor installed by:

- a) Use \rightarrow to get to UNITS/MODE then \downarrow to get to Range, then Store? \rightarrow Yes
(NOTE: liquid must be at zero level)
or
- b) Carefully measure distance from sensor to zero level with tape measure.

MINIMUM RANGE:

At CALIBRATION

- Press \downarrow to get to MinRg
- Press \rightarrow to move the cursor under the digits
- Use \downarrow or \uparrow to set the minimum range

Note: MinRg must be 12" (30.5 cm) for PZ32T sensors and 16" (40.6 cm) for PZ52T sensors except in Hrt mode. For correct tank volume calculation in Hrt mode MinRg must be the actual distance from the end of the sensor to the top of the tank (any value 0). In Level or Range modes the SLT32 will only accept MinRg values 8" (20.3 cm).

- Press \rightarrow to return to MinRg

MAXIMUM RANGE:

- Press \downarrow to get to MaxRg
- Repeat as for MinRg

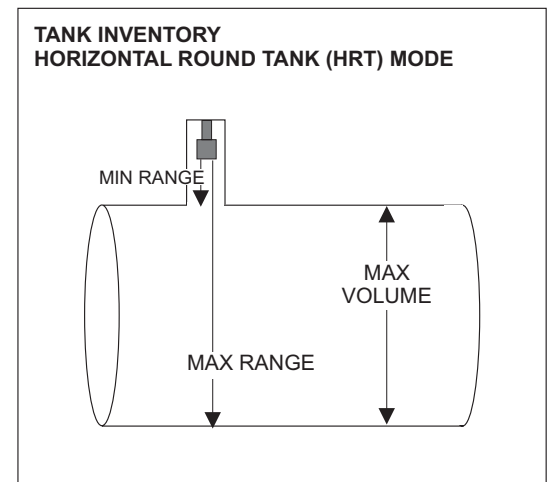
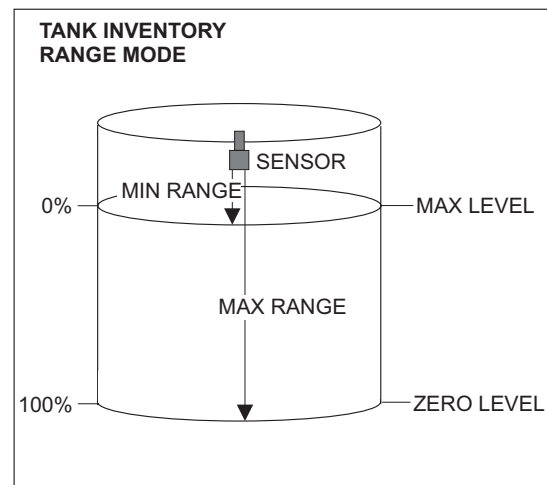
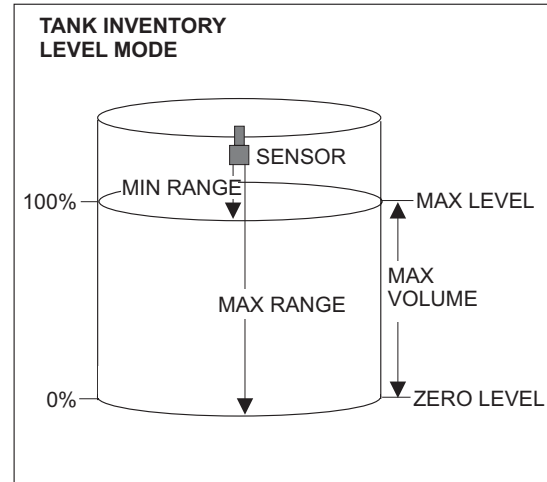

CALIBRATION
- for Open Channel Flow

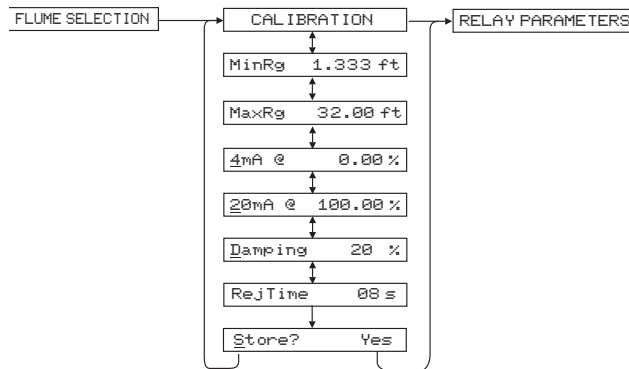

1. Before starting the calibration determine:

- a) MAX RANGE = _____
(Maximum range = distance from the Sensor to Zero level point)
- b) MAX LEVEL = _____
(Maximum level of flow through flume or weir)
- c) MIN RANGE = _____
(Distance from sensor to Max Level)
Minimum range = MAX RANGE - MAX LEVEL
(must be at least 8" / 20.3 cm depending on sensor model).

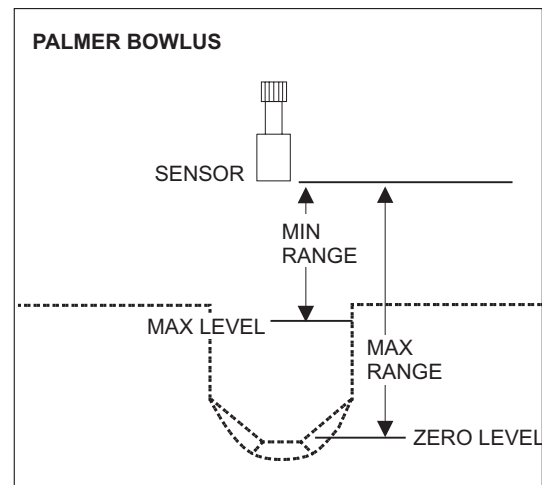

2. Check the maximum range with the sensor installed by:

- a) Use **➡** to get to **UNITS/MODE** then **⬇** to get to **Range**, then **Store? Yes**
(NOTE: flow must be at zero flow)
or
- b) Carefully measure distance from sensor to zero level with tape measure.

NOTE: The SLT32 will not detect targets beyond user entered **MaxRg**.

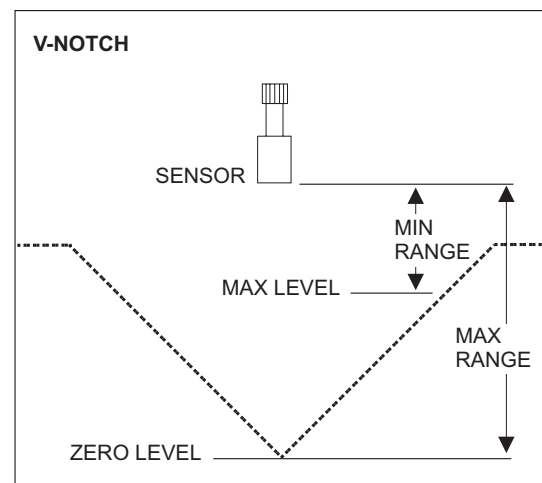

4-20mA CURRENT LOOP OFFSET

Some applications may require the 4-20mA output to be offset so that 4mA or 20mA corresponds to a Level, Range or Flow other than Zero and Full Scale.

4mA at - use \uparrow and \downarrow to set % output for 4mA. It is adjustable from -5% (3.8mA) up to 15% lower than the 20mA setting. Adjustment resolution is 0.05% (0.01mA).

20mA at - use \uparrow and \downarrow to set % output for 20mA (down to 15% greater than the 4mA setting and up to 300%). Adjustment resolution is 0.05% (0.01mA).

DAMPING

Minimum damping allows fast response to level changes. Increasing damping slows the SLT32's response to level changes and is ideal to smooth the display and outputs in turbulent conditions. Damping value is shown in percent (0-99%). Some experimentation may be required to select the optimum damping value. A value of 20% is recommended for most applications. For fast level changes (up to ½ inch/sec - 13 mm/sec), a Damping value of 1% is recommended. Maximum is 99%.

If the SLT32 is unable to obtain repeated echoes the Damping setting will be automatically set to 1% by the instrument.

REJECTION TIME (RejTime)

Rejection Time adjustment is a powerful SLT32 feature to suppress false echoes and the effects of transient targets such as agitators, splashing, or turbulence. Rejection Time is shown in seconds. The time value represents the number of seconds the SLT32 must receive repeated echoes from a new target before indicating its level on the display and outputs. The factory default is 8 seconds and should be ideal for most applications. Decreasing this value allows the SLT32 to respond more quickly to fast level changes, and increasing the time value allows the SLT32 to reject false echoes from slow sweeping agitators, tank filling streams, splashing, severe turbulence and steam. Minimum setting is 1 second (for fast level changes up to ½ inch/sec - 13 mm/sec). Maximum setting is 85 seconds. If the SLT32 is unable to obtain repeated echoes the RejTime setting will be automatically set to 1 second by the instrument.

RELAY PARAMETERS

Each relay can be individually calibrated. Press **↓** to R Function and **→** to select: Off **→** Pulse **→** Temp **→** Level **→** Flow.

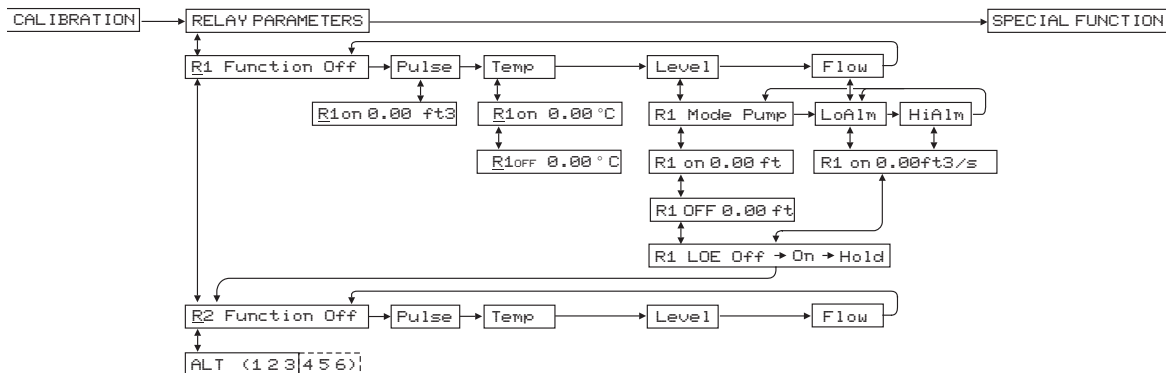

Off mode means the relay will not be energized

Pulse Appears in Flow mode only. Press **↓** and set digits to the flow volume increment required between relay pulses. Use this feature for remote samplers, chlorinators or totalizers. Maximum pulse setting is 999,999. Minimum time between pulses is 1 second and pulse duration is 350 milliseconds.

Temp References temperature reading from the SLT32's ultrasonic sensor (air temperature at the sensor location). Press **↓** and **→** and set the relay On and Off set points.

Level Appears in Level, Range, Volume or HRT modes only. Press **↓** to R Function and **→** to select PUMP, LoAlm (low alarm) or HiAlm (high alarm).

Volume

PUMP mode - press **↓** and **→** and set relay On and Off set points.

LoAlm mode - press **↓** and set relay On point. Relay will be On with levels below this point.

HiAlm mode - press **↓** and set relay On point. Relay will be On with levels above this point.

LOE - press **→** to select Off **→** On **→** Hold. In a loss of echo condition, the (Loss Of Echo) relay will turn Off (de-energize), On (energize) or Hold its current state. Each relay can be individually configured. Press **↓**.

To calibrate a relay for echo loss alarm only, set the relay On and Off set points to exactly the same value, and then set LOE to On mode. The relay will now energize only when an echo loss condition occurs.

- Flow** Appears in Flow mode only. Press **↓** to **R Function** and **➡** to select **Pump**, **LoAlm** (low alarm) or **HiAlm** (high alarm).
- Pump mode** - press **↓** and **➡** and set relay On and Off set point.
- LoAlm mode** - press **↓** and set relay On point. Relay will be energized with levels below the On point and de-energized with levels above the On point.
- HiAlm mode** - press **↓** and set relay On point. Relay will be energized with levels above the On point and de-energized with levels below the On point.
- LOE (Loss Of Echo)** - press **➡** to select **Off ➡ On ➡ Hold**. In a loss of echo condition, the relay will turn Off (de-energize), On (energize) or Hold its current state. Each relay can be individually configured. Press **↓**.

ALT permits relays calibrated in Pump mode to be alternated automatically. Pump alternation allows even pump wear in pumping station applications.

ALT (-None-) indicates that no relays have been programmed in Pump mode.

ALT 123 - Press **➡** to place cursor (underline) under the relay number to be programmed for alternation and press **↑** or **↓** to highlight. Repeat until all relays to be alternated are highlighted.

Note: Alternating pumps must have different On setpoints to alternate correctly, otherwise alternating pumps will turn On at the same time.

PUMP ALTERNATION (R1, R2, R3)

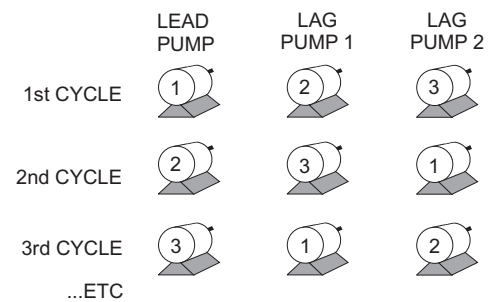

Press **↓** to SStore? YYes and **➡** to Yes. Press **↑** or **↓** to save your Relay settings.

SPECIAL FUNCTIONS

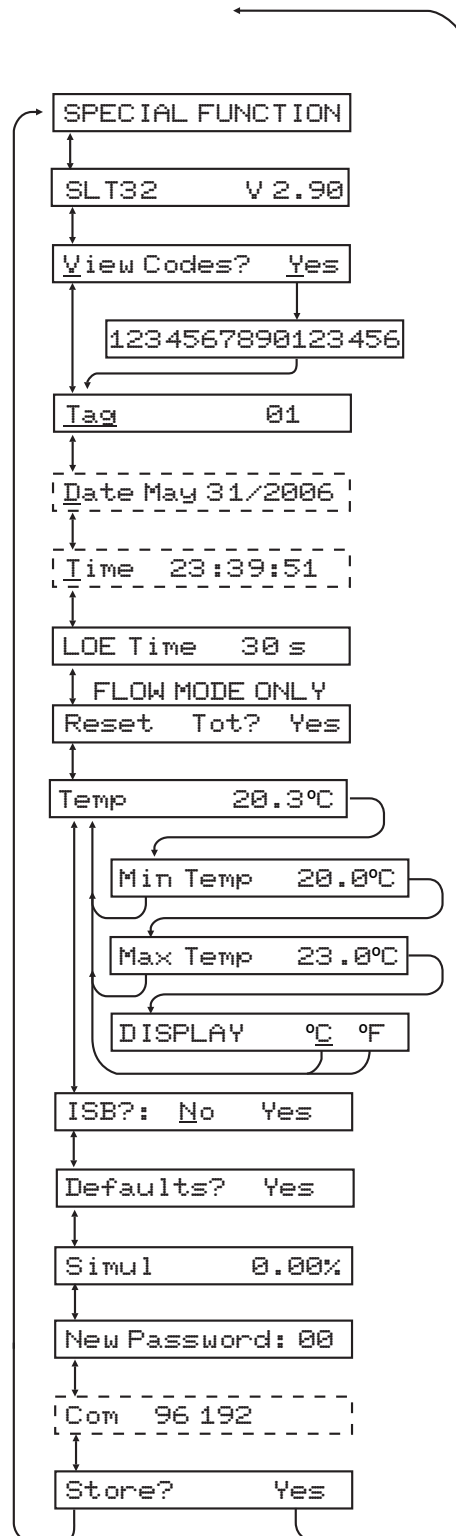

| | |
|-----------------|---|
| SLT32 V2.90 | shows software version installed |
| View Codes? Yes | Select <u>Yes</u> and then ↓ to display an instrument performance code. Faults detected by the instrument are stored in the code and will be requested by Greyline if you call for service or assistance. |
| Tag | Enter Instrument Tag number (0-9999) |
| Date MM DD/YYYY | (with optional Data Logger) Press → and ↑ or ↓ to change Month, Day Year. |
| Time HH:MM:SS | (with optional Data Logger) Press → and ↑ or ↓ to change Hours, Minutes, Seconds |
| LOE TIME | Press → and ↑ or ↓ to change the number of seconds without receiving an echo before the SLT32 displays ECHO LOSS, and Control relays change state as calibrated under Relay Parameters. Factory default is 30 seconds and is recommended for most applications, Minimum is 10 seconds and maximum is 60 seconds. |
| Reset Tot? Yes | (FLOW mode only) Position the cursor under <u>Yes</u> to reset the totalizer. Store this selection at the Store? <u>Yes</u> prompt. |
| Temp 25.0C | Indicates current temperature at the sensor head. Press → to Min Temp and → to Max Temp to display the minimum and maximum temperatures the SLT32 has sensed. Press → to Display °C °F. Position the cursor under °C for celcius display or °F for Farenheight display. Press ↓ to return to TEMP. |
| ISB?: No Yes | Select <u>Yes</u> only when the instrument is equipped with an optional Intrinsic Safety Barrier for sensor mounting in hazardous locations. This setting compensates for the electrical characteristics of an Intrinsic Safety Barrier. |
| Defaults? Yes | Press → 3 times to select <u>Yes</u> . Store to erase <u>all</u> user settings and return instrument to factory default settings. |
| Simul | The Output simulation function controls the 4-20mA output, digital display and control relays. Use it to simplify calibration of remote devices such as chart recorders or remote displays, and to test Relay set-points. Simulation digits are shown as a percentage of full scale. Use the ↑ and ↓ Arrow keys to simulate 0% (4mA), 100% (20mA), and increments of .05% (.008mA). Increments will automatically accelerate when the ↑ or ↓ is continuously pressed. |
| New Password | position cursor under digits and set new number between 00 and 99. |
| Com 96 192 | Optional (with Data Logger) Speed of RS-232C transmission. Select 9600 or 19200 baud rate (must be set to match baud rate in 'Greyline Logger' software and any modems used for serial communication). |

SENSOR MOUNTING/LOCATION
- Tank Level/Inventory Applications

Each SLT32 Level Transmitter includes a non-contacting ultrasonic sensor. The sensor must be installed in a position to obtain unobstructed echoes from the liquid or material being measured.

Mount the sensor away from pipes, ladders, or structural members which might cause continuous false echoes.

BAD

GOOD

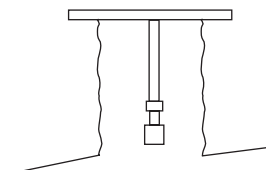
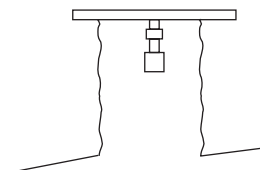
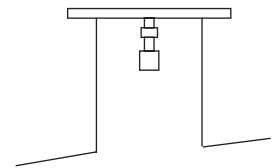
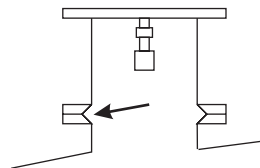
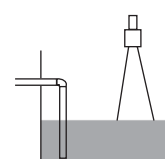
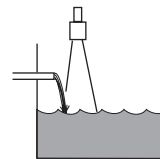
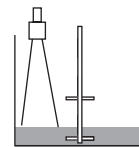
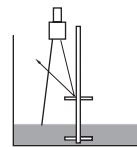
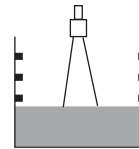
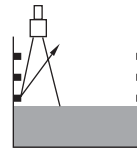
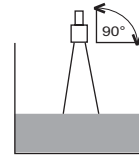
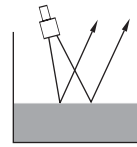

SOLIDS AND POWDERS

SENSOR MOUNTED AWAY FROM MATERIAL PATH. COARSE SOLIDS WILL USUALLY RETURN AN ECHO EVEN IF AT AN ANGLE

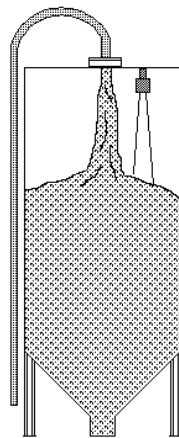

FINE POWDERS MAY NEED SENSOR TILTED NORMAL TO SURFACE TO OBTAIN GOOD ECHOES

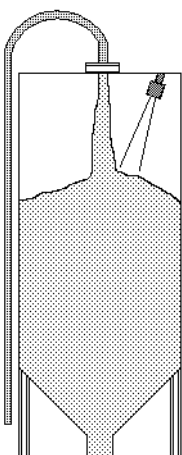

SENSOR MOUNTING LOCATION
- Tank Level/Inventory Applications

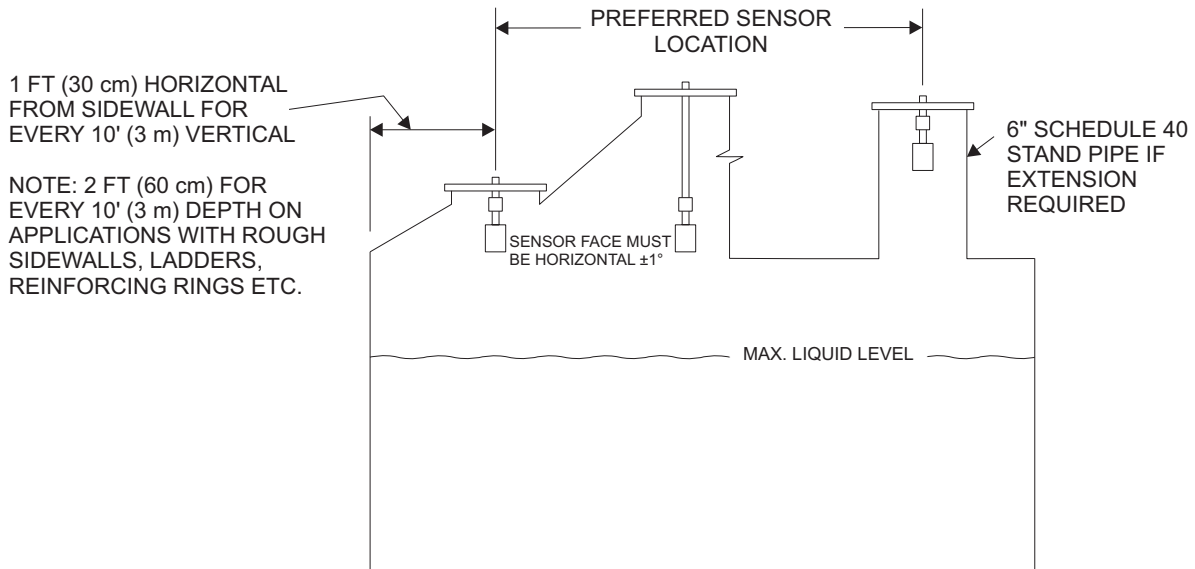

SENSOR MOUNTING

Each sensor is equipped with a $\frac{3}{4}$ inch "isolation coupling" which MUST be used in your installation. A threaded nipple or length of conduit may be used to position the sensor at the desired height.

The sensor should be hand-tightened (like a light bulb) by turning the sensor stem only. DO NOT use a wrench and do not over tighten. DO NOT clamp the sensor below the isolation coupling.

SENSOR MOUNTING METHODS

Notes:

1. Use the 3/4" NPT "Isolation Coupling" supplied and *hand tighten* only. Do not clamp sensor body or stem.
2. Locate the sensor 1 ft (30 cm) from the sidewall or obstruction for every 10 ft (3 m) depth.
3. *Do not* mount in direct sunlight.
4. Extend sensor cable up to 500 ft (150 m) with RG62AU coaxial only.

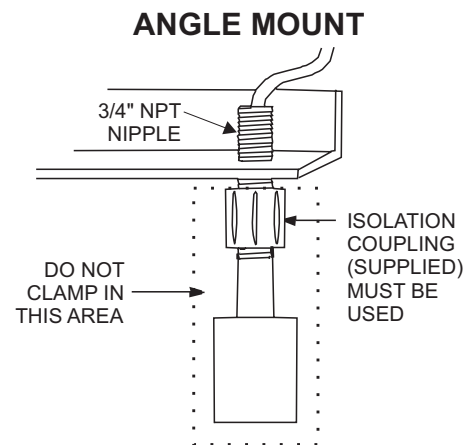
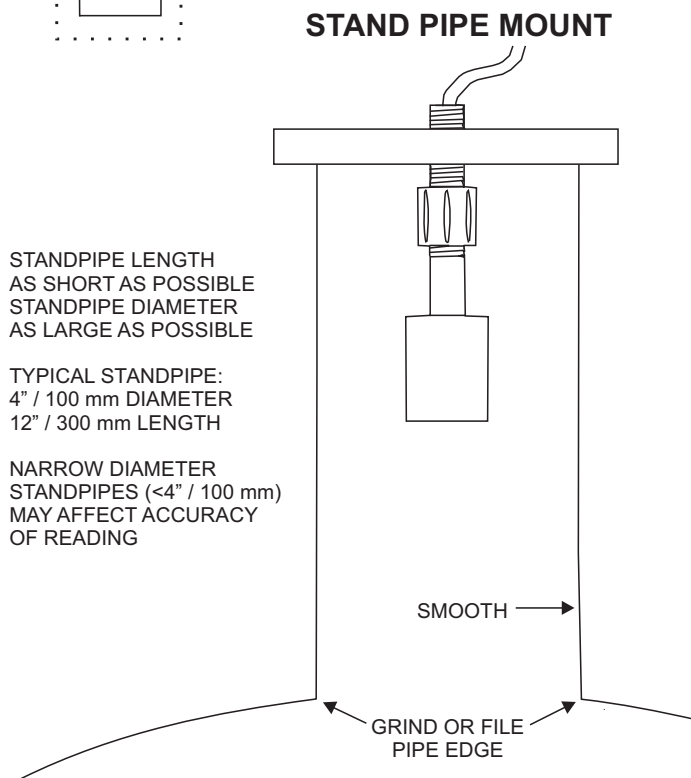
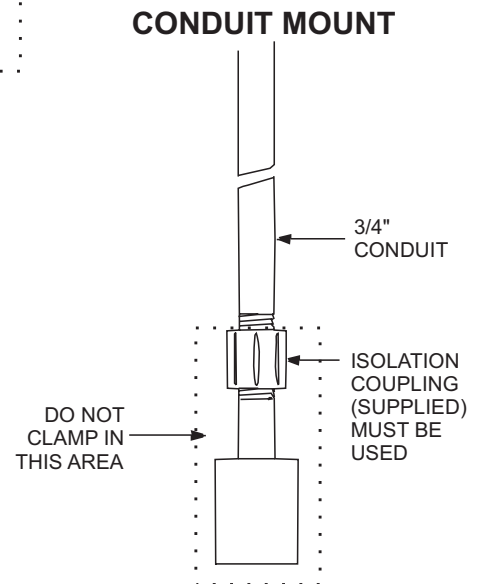
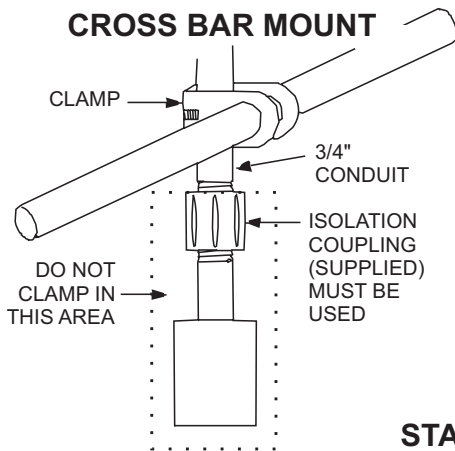
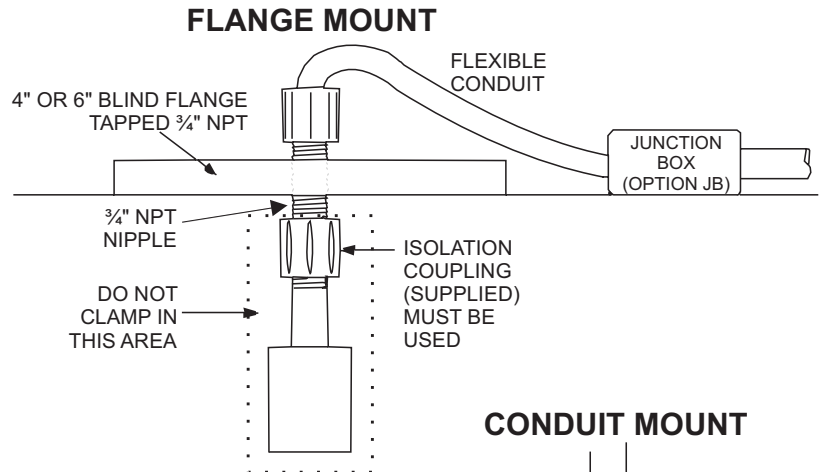

SENSOR MOUNTING/LOCATION
- Open Channel Flow Applications

Each sensor is equipped with a 3/4 inch isolation coupling which **MUST** be used in your installation. A threaded nipple or length of conduit may be used to position the sensor at the desired height. The sensor should be hand-tightened by turning the sensor stem only. **DO NOT** use a wrench and do not over tighten.

IMPORTANT: Follow the flume manufacturer's directions for transducer location. The transducer should be centered above the flume approach section and mounted 12"/30.5 cm (minimum) above the maximum liquid level (depending on sensor model).

The transducer should be protected from physical damage and the transducer cable should be routed in a separate metal conduit.

Because the sensor is equipped with a temperature sensor, it should be shielded from direct sunlight.

Use the PVC "isolation coupling" supplied with the sensor and hand-tighten the sensor/coupling assembly onto your mounting stand. Do not clamp directly to the sensor or to the isolation coupling.

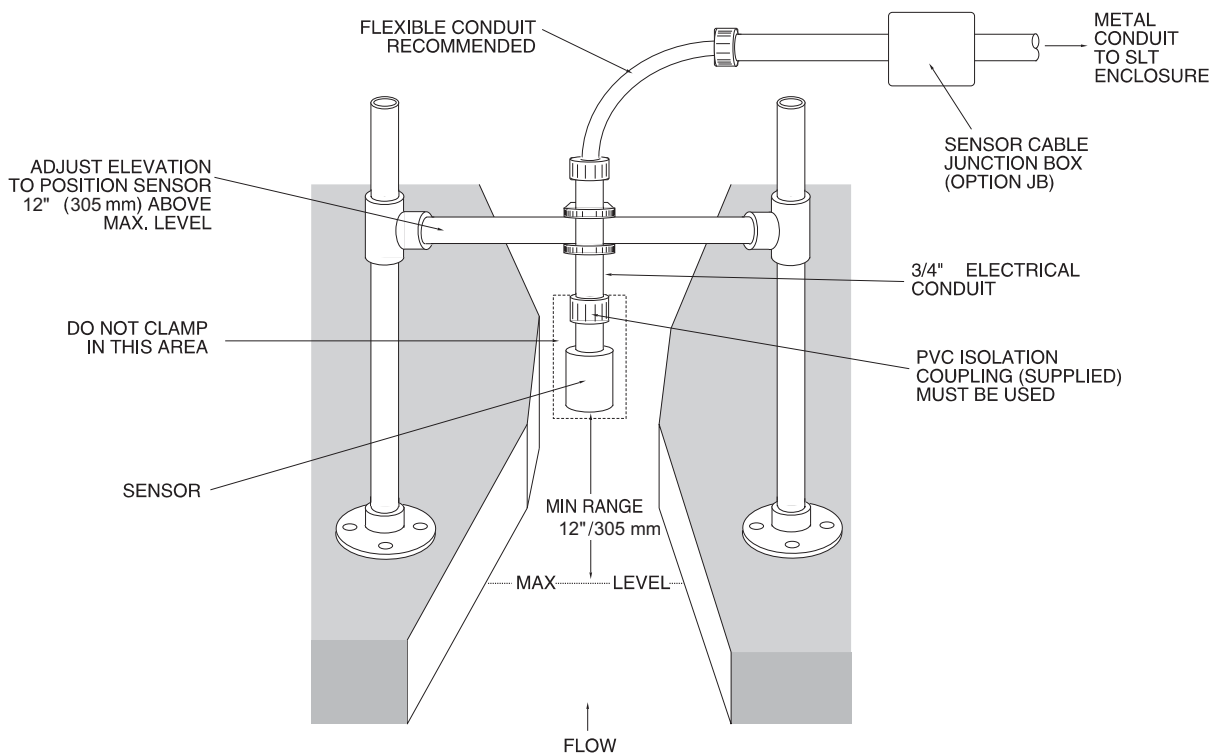

**TYPICAL TRANSDUCER POSITIONING
FOR FLUMES AND WEIRS**

Always refer to the flume or weir manufacturer's instructions for correct measurement point upstream from the flume or weir. Location of the sensor is critical for accurate flow measurement.

If manufacturer's instructions are not available, the following guidelines are generally accepted.

1. PARSHALL FLUME:

Position the sensor at $\frac{2}{3}$ Approach as illustrated above. Sensor height must be 12" / 30.5 cm or more above the highest water level.

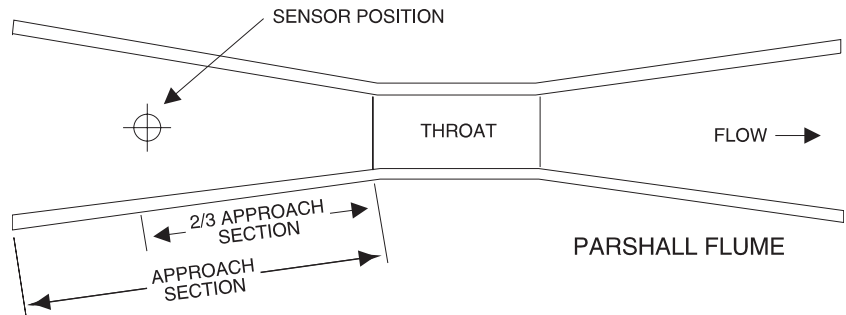

2. PALMER BOWLUS FLUMES:

Position the sensor at $\frac{1}{2}$ the flume Diameter upstream from the throat of the flume. Sensor height must be 12" / 30.5 cm (depending on sensor model) or more above the highest water level.

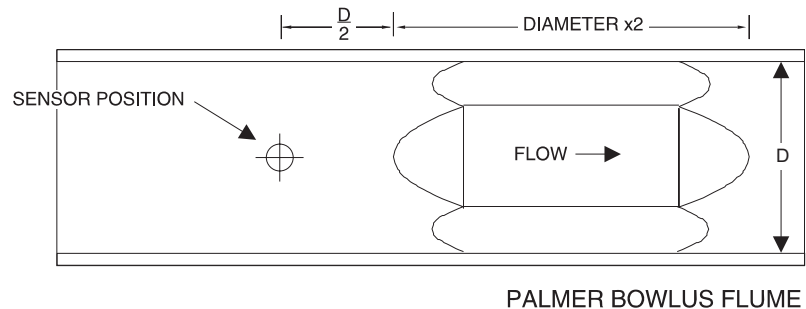

3. V-NOTCH WEIRS

Position the sensor at 3 x maximum Head upstream from the weir plate. Sensor height must be 12" / 30.5 cm (depending on sensor model) or more above the highest water level.

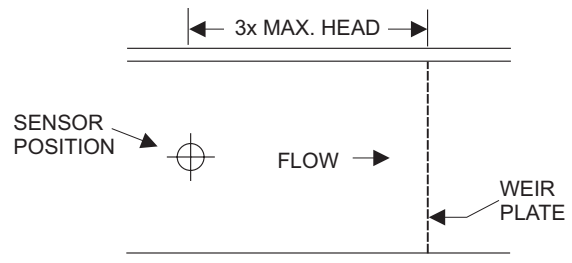

STILLING WELLS

Stilling wells are recommended to reduce the effects of turbulence as water flows through the flume or weir. The SLT32 sensor is centered over the stilling well. Sensor height must be 12" / 30.5 cm or more above the highest water level. The well must be kept clean of sediments and deposits on the side walls.

ZERO POSITIONING OF SENSOR
- Open Channel Flow Applications

Locate the sensor at the position upstream from the throat of the flume or weir plate as recommended by the manufacturer. A technique for accurate sensor height adjustment is shown:

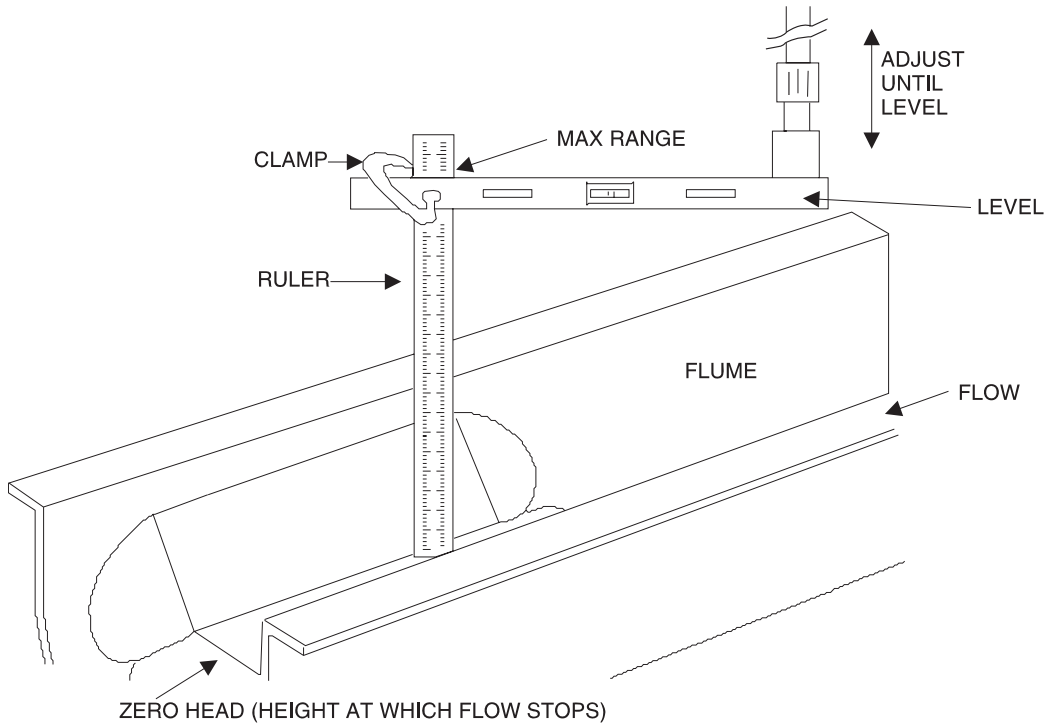

ENCLOSURE INSTALLATION

Locate the enclosure within 500 ft (150 m) of the sensor. It can be wall mounted with four mounting screws (supplied) or panel mounted with Option PM Panel Mounting Kit from Greyline Instruments. Avoid mounting the enclosure in direct sunlight to protect the electronics from damage due to overheating and condensate. In high humidity atmospheres, or where temperatures fall below freezing, Option TH Enclosure Heater and Thermostat is recommended. Seal conduit entries to prevent moisture from entering enclosure.

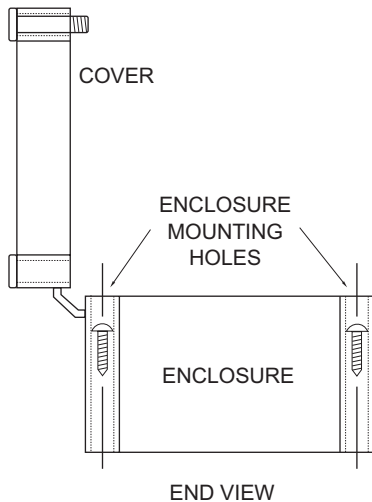

NEMA4X (IP66) WITH CLEAR COVER

1. Open hinged enclosure cover.
2. Insert #8 screws and washers through the four enclosure mounting holes to secure enclosure to wall or mounting stand.
3. Close cover.

Additional conduit holes can be cut in the end of the enclosure when required. Use a hole saw or Greenlee-type hole cutter to cut the required holes.

Note: This non-metallic enclosure does not automatically provide grounding between conduit connections. Grounding must be provided as part of the installation. Ground in accordance with the requirements of the National Electrical Code. System grounding is provided by connecting grounding wires from all conduit entries to the steel mounting plate or another point which provides continuity.

ERROR/WARNING MESSAGES

| | |
|-------------------------------------|--|
| "ECHO LOSS"(flashing) | No valid echoes received within the LOE TIME setting. See FIELD TROUBLESHOOTING (F). In Level mode the SLT32 will hold the display and outputs at the last reading until a new echo is received. In FLOW mode it will display 0.00 and totalization will stop until an echo is received. Refer to ECHO STRENGTH instructions. |
| Er: ILLEGAL MinRg | The value entered for MinRg (Minimum Range) is less than 8"(20.3 cm). MinRg must be greater than or equal to 8" (20.3 cm) for PZ15 sensors. Minimum Range for PZ32T sensors must be greater than or equal to 12"/30.5 cm and for optional PZ52T sensor must be greater than or equal to 16" (40.6 cm). |
| Er: ILLEGAL UNITS | Your choice of UNITS exceeds a maximum value of 9,999,999. Use US MGD, Imp MGD or m3/d so that UNITS will be 9,999,999 or less. |
| Err: ILLEGAL SPAN | <ol style="list-style-type: none"> 1. The value entered for MaxRg is the same or less than MinRg +2". Maximum range <u>must</u> be greater than minimum range and less than 102 ft. (31.09 m). (Note: to invert the scale and outputs, choose Level instead of Range selection in the UNITS/MODE menu.) 2. For Rectangular Weirs with End Contractions, the SPAN (MaxRg - MinRg) must be less than 1/2 the weir size (eg: 12" crest width, SPAN must be 6" or less). |
| - or - | Your choice of Units exceeds 9,999,999. Use USMG/d, IMG/d or m3/d so that Units will be 9,999,999 or less |
| ERR: ILLEGAL SETPOINTS | ON or OFF setpoint is < MinRg or > MaxRg |
| NORMAL / REVERSED SET POINTS MIXED! | <p>Relays have been selected for Pump Alternation and have been calibrated in opposite modes. Any alternating relays must be calibrated in the same mode:</p> <ol style="list-style-type: none"> 1. with ON setpoint > OFF setpoint, or 2. with OFF setpoint > ON setpoint |
| TEMP * 23.5 C | * Indicates Temperature Compensation fault. Check sensor connections. |
| ECHO TOO CLOSE | Indicates that the target is less than MinRg distance from the sensor(too close to the sensor). |
| !! SENSOR OPEN ! | Instrument has detected sensor connection/cable Open. |
| ! SENSOR SHORTED ! | Instrument has detected sensor connection/cable Shorted. |

FIELD TROUBLESHOOTING

SYMPTOMS

CHECK

| | | |
|------------------------|--------------------|---|
| Display | - full scale | A |
| | - zero | B |
| | - erratic - random | C |
| | - drifting up | D |
| | - drifting down | E |
| ECHO LOSS prompt | - flashing | F |
| Calibration Non-Linear | | H |

SYMPTOMS FAULTS

SOLUTIONS

Unit "See's" Wrong Target Due To:

| | | |
|---------|---------------------------------------|--|
| A | - sensor cover not removed | - remove protective cover after installation |
| A,C,D,F | - sensor not aimed correctly | |
| A,D,F | - dust/dirt buildup on sensor | - clean carefully (do not scratch sensor face) |
| A,D,F | - condensation on sensor | - lower sensor |
| | | - insulate sensor mounting location |
| | | - increase MinRg (CALIBRATION menu) by 1-3" / 2.5-7.5 cm |
| | | - wipe sensor face and body with Rain-X |
| A,D | - sensor mounting stand pipe | - lower Sensor below stand pipe intrusion |
| | - too long / - too narrow | |
| | - dirty / - gasket intruding | |
| C,E | - very turbulent flow in open channel | - increase RejTime (CALIBRATION menu) |
| | | - install stilling well on flume or weir |
| C,E | - very turbulent level in tank | - increase RejTime (CALIBRATION menu) |
| | | - change tank fill method |

Unit Picks-Up Interference Due To:

| | | |
|-----|--|---|
| A,C | - noise from high pressure fill | - install submerged fill pipe |
| A,D | - sensor coupling over tightened | - hand tighten only (like a light bulb) |
| A,D | - sensor coupling not used | - use coupling supplied |
| C | - other ultrasonic unit in close proximity | - synchronize |

Electrical interference:

| | | |
|---|--|---------------------------------------|
| C | - sensor cable connections reversed | |
| C | - through sensor cable | - use properly grounded metal conduit |
| C | - sensor cable extended and junction not insulated | - use metal Junction Box |
| C | - through enclosure | - use metal enclosure |

- | | | |
|---|--|---|
| C | - through 4-20mA output cable | - use shielded twisted pair (shielded to AC ground) - use grounded metal conduit |
| C | - wiring or installation close to variable speed drive or inverter | - follow V.S.D. manufacturer's instructions for Drive grounding, wiring and shielding |

Unit Receives No Return Echo Due To:

- | | | |
|-------|--------------------------|---|
| C,F,E | - foam on liquid surface | - use stilling well (open channel flow) |
| B | - target beyond MaxRg | - recalibrate |
| E | - calibration error | - ISB No selected in SPECIAL FUNCTIONS and instrument has an optional ISB |
| F | - sensor damaged | - remove sensor from mounting and aim at a flat, stable target to test |
| F | - sensor misalignment | - check with a level |

Wiring Problems Due To Sensor Cable:

- | | | |
|--------|---|--|
| A,C,F, | - open circuit | - check connections/continuity (8850 to 12700 ohms max./-30°C to +70°C) |
| B,F | - short circuit | - check connections/continuity (8850 ohms min.) |
| F | - too long (max 500 ft., 150 m) | |
| C | - bundled/run in conduit with power cable | |
| C | - sensor ground shorted to conduit/enclosure | - insulate |
| A | - extended with wrong type of wire | - use RG62A/U coaxial only |
| C | - close to high voltage/large motors | |
| C | - AC chassis/ground missing on instrument power connections | |

Non-Linearity Due To:

- | | | |
|-----|--|--|
| H | - vapour | - dissipate fumes, Calibration in-situ |
| H | - zero not set accurately | - see "Zero Positioning of Sensor" |
| H | - wrong flume, or K&n selected (FLOW mode) | - select correct flume |
| D,E | - calibration error | - ISB Yes selected in SPECIAL FUNCTIONS menu and instrument does not have an ISB |

**PZxx Series Sensors
Troubleshooting**

Resistance measured across the coaxial cable ends (between the shield and centre wire) by multimeter indicates ambient temperature.

Resistance vs. Temperature

Values are in Ohms

| Temp °C | +0 | +1 | +2 | +3 | +4 | +5 | +6 | +7 | +8 | +9 |
|------------|------------|------------|------------|------------|------------|------------|------------|------------|------------|------------|
| 0 | 10000.0 | 10039.0772 | 10078.1429 | 10117.1970 | 10156.2396 | 10195.2706 | 10234.2901 | 10273.2980 | 10312.2944 | 10351.2792 |
| 10 | 10390.2525 | 10429.2142 | 10468.1644 | 10507.1030 | 10546.0301 | 10584.9456 | 10623.8496 | 10662.7420 | 10701.6229 | 10740.4922 |
| 20 | 10779.3500 | 10818.1962 | 10857.0309 | 10895.8540 | 10934.6656 | 10973.4656 | 11012.2541 | 11051.0310 | 11089.7964 | 11128.5502 |
| 30 | 11167.2925 | 11206.0232 | 11244.7424 | 11283.4500 | 11322.1461 | 11360.8306 | 11399.5036 | 11438.1650 | 11476.8149 | 11515.4532 |
| 40 | 11554.0800 | 11592.6952 | 11631.2989 | 11669.8910 | 11708.4716 | 11747.0406 | 11785.5981 | 11824.1440 | 11862.6784 | 11901.2012 |
| 50 | 11939.7125 | | | | | | | | | |

© 2009 Minco, All Rights Reserved

Values are in Ohms

| Temp °F | +0 | +1 | +2 | +3 | +4 | +5 | +6 | +7 | +8 | +9 |
|------------|------------|------------|------------|------------|------------|------------|------------|------------|------------|------------|
| 30 | | | 10000.0 | 10021.7110 | 10043.4184 | 10065.1223 | 10086.8226 | 10108.5193 | 10130.2125 | 10151.9021 |
| 40 | 10173.5881 | 10195.2706 | 10216.9495 | 10238.6249 | 10260.2967 | 10281.9649 | 10303.6295 | 10325.2906 | 10346.9481 | 10368.6021 |
| 50 | 10390.2525 | 10411.8993 | 10433.5426 | 10455.1823 | 10476.8184 | 10498.4510 | 10520.0800 | 10541.7054 | 10563.3273 | 10584.9456 |
| 60 | 10606.5604 | 10628.1716 | 10649.7792 | 10671.3832 | 10692.9837 | 10714.5806 | 10736.1740 | 10757.7638 | 10779.3500 | 10800.9327 |
| 70 | 10822.5118 | 10844.0873 | 10865.6593 | 10887.2277 | 10908.7925 | 10930.3538 | 10951.9115 | 10973.4656 | 10995.0162 | 11016.5632 |
| 80 | 11038.1067 | 11059.6466 | 11081.1829 | 11102.7156 | 11124.2448 | 11145.7704 | 11167.2925 | 11188.8110 | 11210.3259 | 11231.8373 |
| 90 | 11253.3451 | 11274.8493 | 11296.3500 | 11317.8471 | 11339.3406 | 11360.8306 | 11382.3170 | 11403.7999 | 11425.2792 | 11446.7549 |
| 100 | 11468.2270 | 11489.6956 | 11511.1606 | 11532.6221 | 11554.0800 | 11575.5343 | 11596.9851 | 11618.4323 | 11639.8759 | 11661.3160 |
| 110 | 11682.7525 | 11704.1854 | 11725.6148 | 11747.0406 | 11768.4629 | 11789.8816 | 11811.2967 | 11832.7082 | 11854.1162 | 11875.5206 |
| 120 | 11896.9215 | 11918.3188 | 11939.7125 | | | | | | | |

© 2009 Minco, All Rights Reserved

FUSE REPLACEMENT

1. Turn OFF power
2. Loosen 2 Phillips corner screws and remove power module from the chassis.
3. Locate fuse on Power Board
4. Replace fuse with 2 Amp/250V, 5 x 20mm fuse
5. Reinstall power module in the chassis.

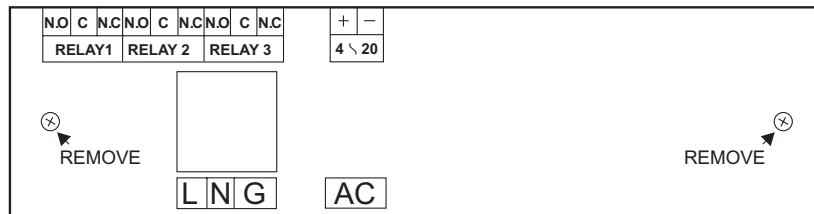

POWER MODULE

INSTALLATION CONSIDERATIONS IN NOISY ENVIRONMENTS

Greyline's instruments are designed with a high degree of noise immunity for use in industrial environments. Noise interference can still occur if certain minimal considerations are not adhered to when installing the equipment.

Noise

When relay contacts are used to switch inductive loads, such as auxiliary relays or solenoids, extremely large voltage spikes can be generated when the relay contact opens producing what is known as Radio-Frequency Interference or "RFI" or just "noise".

These voltage spikes can also be coupled from power lines that are powering equipment that contains S.C.R. circuitry such as VSD controllers, or lines that are actuating AC or DC solenoids or actuators. There are three major ways that noise spikes can enter the instrument.

1. Via the AC power input lines.
2. Via the Sensor input line.
3. Via the output lines (relay connections and 4-20mA output)

Symptoms of RFI produced by relay activation

If the instrument shows the following symptoms suspect RFI.

- The Alphanumeric display (bottom display) blinks continuously as if power was being turned off and on (i.e instrument resets continuously).
- Keypad does not respond or instrument resets to run mode from inside the menu.
- The instrument calibration is lost.
- The message "MEM CORRUPTED" is shown.
- Relays trip erratically.
- Both digital displays go blank as if power was OFF.

Symptoms of noise on sensor input and/or 4-20mA lines

- Instruments readings are erratic or high when actual value is low
- The Alphanumeric display (bottom display) blinks continuously as if power was being turned off and on i.e instrument resets continuously.
- Instrument "beeps" intermittently even if the Keypad is not pressed.

Avoiding noise problems

1. It is recommended that electronic instruments be connected to a relatively clean AC power source. Use an AC power filter or isolation transformer if necessary.
2. The sensor input line and the control lines (AC or DC) should not be run in the same conduit . The sensor input should be separated from wires going to inductive loads such as motors, solenoids, relays and contactors. For best results run the sensor wire in a separate metal conduit. A two-conductor shielded cable is recommended for the 4-20mA output, the shield should be connected to chassis ground at the instrument only.
3. For the relay connections, one of most overlooked sources of trouble, noise suppressors are recommended. Also known as “snubbers” these devices will limit the large spikes produced when the relay opens, stopping the RFI and also protecting the relay contacts from degrading.

NOISE SUPPRESSION ON RELAY OUTPUT

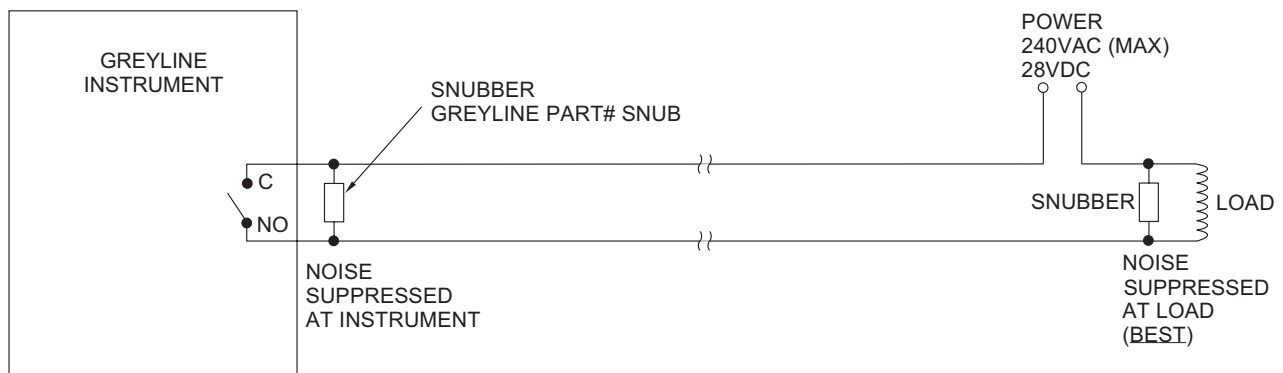

APPLICATIONS HOTLINE

For applications assistance, advice or information on any Greyline Instrument contact your Sales Representative, write to Greyline or phone the Applications Hotline below:

| | | |
|----------------|---|-------------------|
| United States: | Tel: 315-788-9500 | Fax: 315-764-0419 |
| Canada: | Tel: 613-938-8956 | Fax: 613-938-4857 |
| Toll Free: | 888-473-9546 | |
| Email: | info@greyline.com | |
| Web Site: | http://www.greyline.com | |

Greyline Instruments Inc.

Canada
16456 Sixsmith Drive
Long Sault, Ont. K0C 1P0

USA:
105 Water Street
Massena, NY 13662

PRODUCT RETURN PROCEDURE

Instruments may be returned to Greyline for service or warranty repair.

1 Obtain an RMA Number from Greyline -

Before shipping a product to the factory please contact Greyline by telephone, fax or email to obtain an RMA number (Returned Merchandise Authorization). This ensures fast service and correct billing or credit.

When you contact Greyline please have the following information available:

1. Model number / Software Version
2. Serial number
3. Date of Purchase
4. Reason for return (description of fault or modification required)
5. Your name, company name, address and phone number

2 Clean the Sensor/Product -

Important: unclean products will not be serviced and will be returned to the sender at their expense.

1. Rinse sensor and cable to remove debris.
2. If the sensor has been exposed to sewage, immerse both sensor and cable in a solution of 1 part household bleach (Javex, Clorox etc.) to 20 parts water for 5 minutes. Important: do not immerse open end of sensor cable.
3. Dry with paper towels and pack sensor and cable in a sealed plastic bag.
4. Wipe the outside of the enclosure to remove dirt or deposits.
5. Return to Greyline for service.

3 Ship to Greyline -

After obtaining an RMA number please ship the product to the appropriate address below:

*Canadian and International
Customers:*

Greyline Instruments Inc.
16456 Sixsmith Drive
Long Sault, Ont. K0C 1P0

RMA#

USA

Customers:

Greyline Instruments Inc.
204 150th Avenue
Madeira Beach, FL 33708

RMA#

LIMITED WARRANTY

Greyline Instruments warrants, to the original purchaser, its products to be free from defects in material and workmanship for a period of one year from date of invoice. Greyline will replace or repair, free of charge, any Greyline product if it has been proven to be defective within the warranty period. This warranty does not cover any expenses incurred in the removal and re-installation of the product.

If a product manufactured by Greyline should prove defective within the first year, return it freight prepaid to Greyline Instruments along with a copy of your invoice.

This warranty does not cover damages due to improper installation or handling, acts of nature, or unauthorized service. Modifications to or tampering with any part shall void this warranty. This warranty does not cover any equipment used in connection with the product or consequential damages due to a defect in the product.

All implied warranties are limited to the duration of this warranty. This is the complete warranty by Greyline and no other warranty is valid against Greyline. Some states do not allow limitations on how long an implied warranty lasts or limitation of incidental or consequential damages, so the above limitations or exclusions may not apply to you.

This warranty gives you specific legal rights, and you may also have other rights which vary from state to state.

Greyline Instruments Inc.

APPENDIX A - OPTIONS

**EXTRA SENSOR CABLE
(OPTION XC)**

Each Greyline SLT32 includes 25 ft. (7.6m) RG62AU coaxial cable. Additional RG62AU coaxial cable and Cable Junction Box (Option JB) may be ordered with the Flow Monitor, or the cable may be spliced and extended up to 500 ft (152m) as required during installation. No adjustment is required when the sensor cable is extended or shortened. Use only RG62AU (or RG62U) coaxial cable which is available from Greyline Instruments or your local distributor. Nominal impedance of RG62AU cable is 93 ohms.

Extended sensor cable must be installed in metal conduit to prevent interference. Do not use BNC coaxial connectors (TV cable type). Recommended installation with a metal junction box is illustrated below:

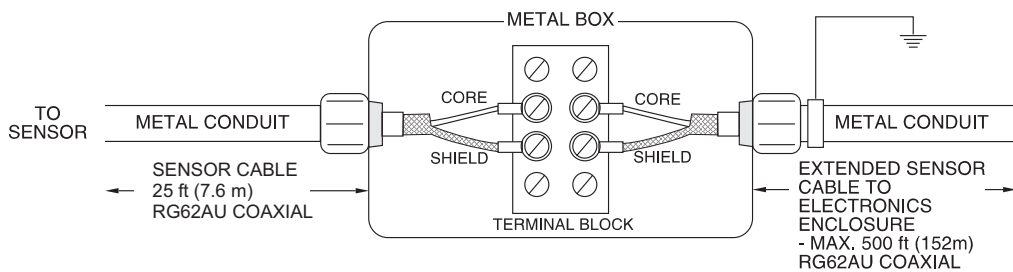

Note: Optional Watertight steel NEMA4 Junction Boxes with terminal strips (Option JB) are available from Greyline Instruments.

**DIMENSIONS
OPTION JB - JUNCTION BOX**

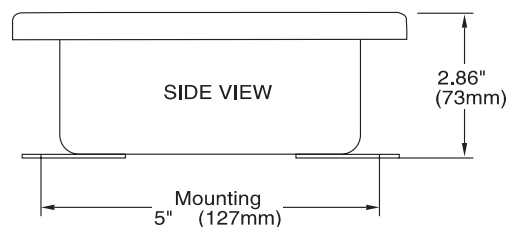
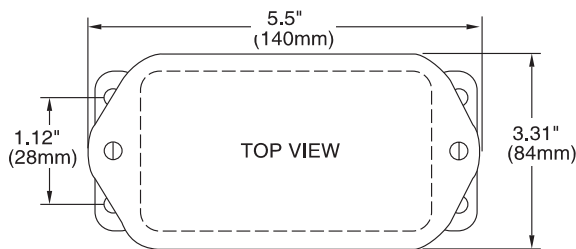

SENSOR INTRINSIC SAFETY - OPTION ISB

SENSOR MODELS PZ32T/PZ32TE/PZ15 (with built-in temperature compensation)

When connected through an Intrinsic Safety Barrier, the Greyline PZ32T, PZ32TE and PZ15 sensors are CSA certified for installation in a hazardous location rated:

- Class I, Groups C,D
- Class II, Groups E, F and G
- Class III

Intrinsic Safety Barriers may be ordered with the Greyline instrument and are supplied mounted in the Greyline instrument enclosure. Replacement barrier fuses (Part No. ISB-011239) may be purchased separately. Barriers must be installed in the sensor cable between the safe and hazardous locations, and must be mounted in either the safe or Div. 2 area. Barriers may be plate, busbar or rail mounted.

Intrinsic Safety Barrier Specifications: Certified, rated 9.3V max, 25 ohms min. (Recommended: Stahl Model 9001/02-093-390-101).

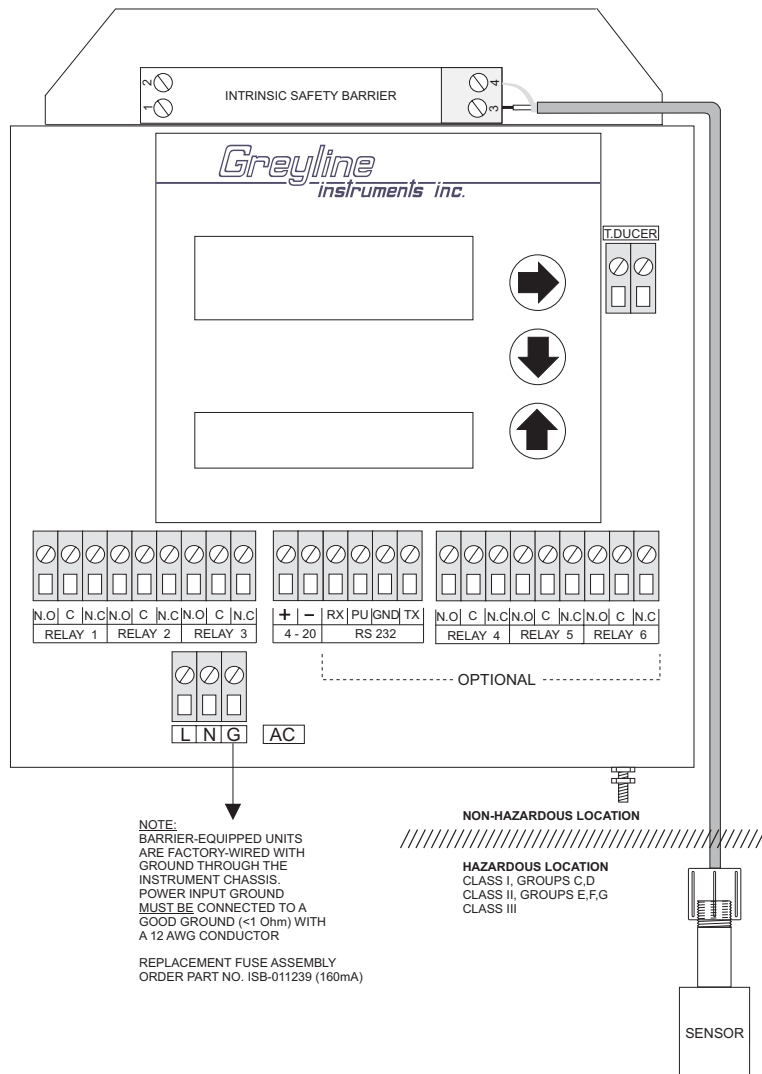

ENCLOSURE HEATER AND THERMOSTAT - Option TH

Instruments can be factory-equipped with an Enclosure Heater and Thermostat. The Thermostat is factory set to turn ON at 40°F (4.5°C) and OFF at 60°F (15.5°). Power consumption is 15 Watts.

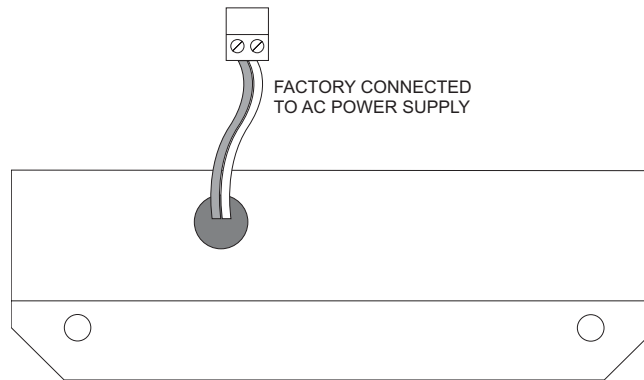

**POWER INPUT OPTION
9-36VDC**

SLT32 Level & Flow Monitors may be ordered factory-configured for 9-36VDC power input.

QUICK BENCH TEST:

Connect Sensor as shown below, then Power. When properly connected figures will show on the large LCD display. Test operation of the SLT32 by holding the sensor steadily and aiming at a flat, stable target 12 to 28" (305 to 711 mm) away from the end of the sensor. Allow a few seconds for the SLT32 to lock onto the target before displaying its distance. The SLT32 will now display Range in ft or cm (factory calibration).

CONNECTIONS:

POWER INPUT: Connect 9-36VDC/0.5 Amps to the + and - terminals. The Power Input GND must be connected to the nearest Ground pole. A 1 amp fuse in line is recommended. Power Consumption is 5.2 W maximum.

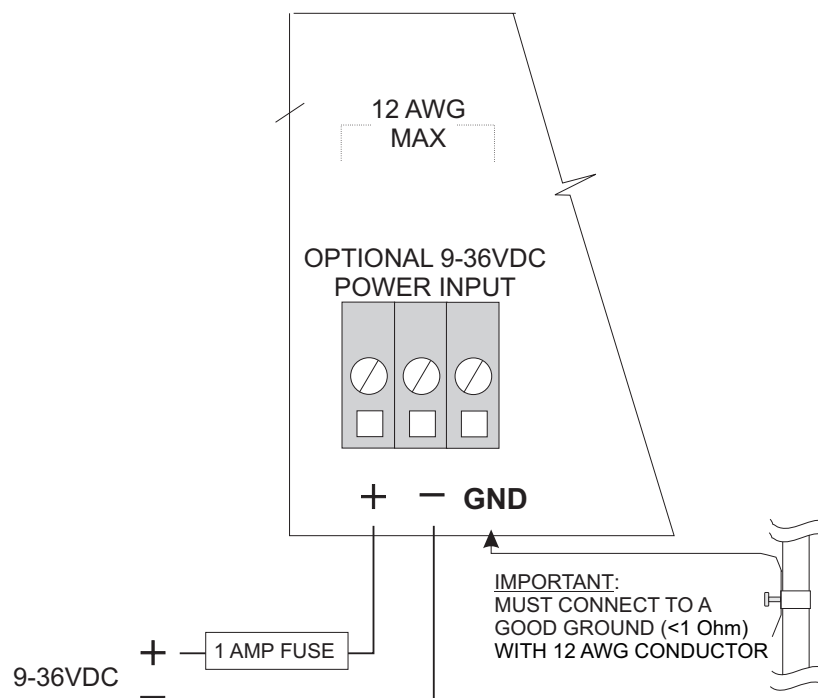

DATA LOGGER MENU (Optional)

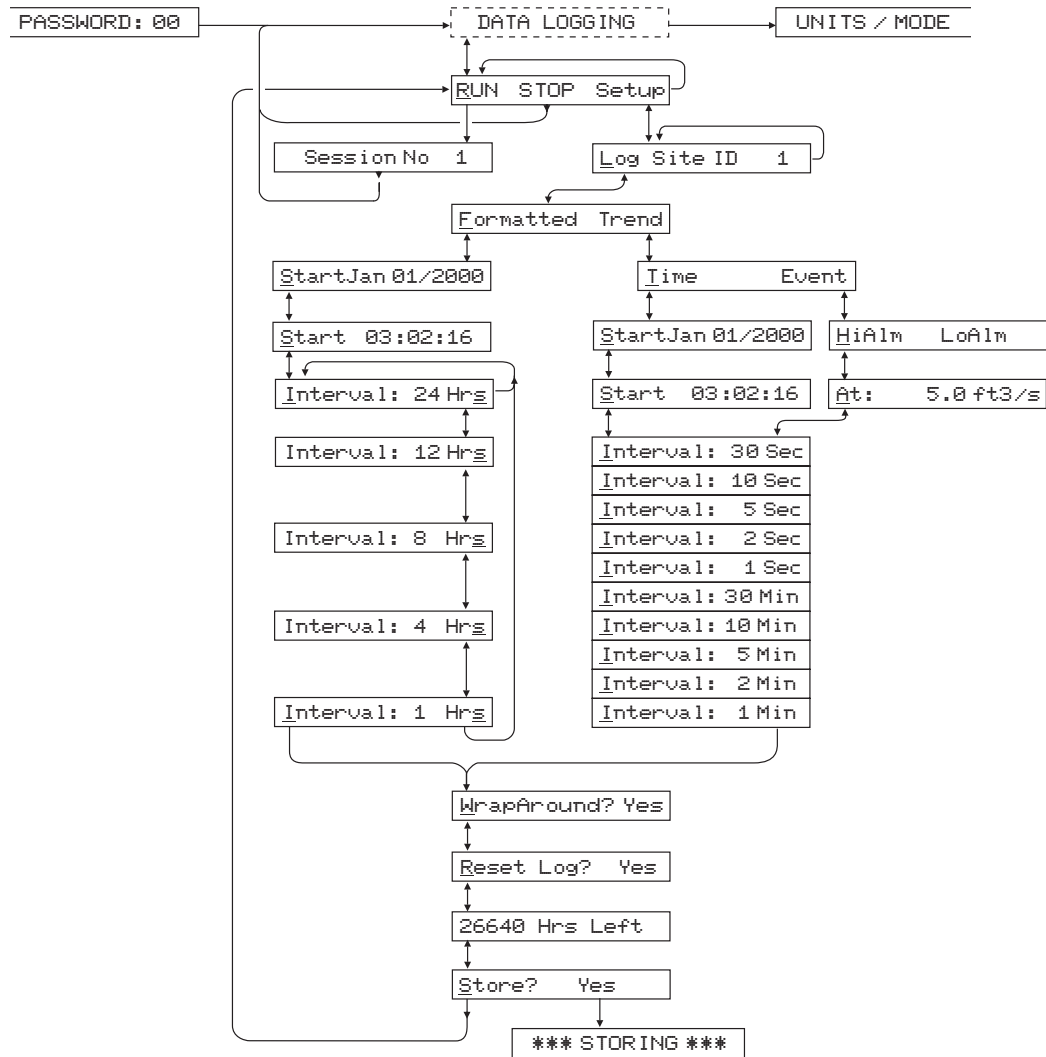

DATA LOGGING (Optional)

Setup

From RUN STOP SETUP press \rightarrow to SETUP and then \downarrow to Log Site ID 0. Press \rightarrow to position the cursor under the numeral and \downarrow or \uparrow to change the numerals. The “Site ID” number is retained with data logging sessions to identify logs stored from different locations.

Formatted Data

Press \downarrow from Log Site ID and press \downarrow from Formatted. “Formatted” data stores a summary of flow readings over a user-selectable time period. The summary includes:

DATE and TIME
Interval TOTAL
Interval AVERAGE
Interval MAX FLOW
Interval MAX FLOW TIME
Interval MIN FLOW
Interval MIN FLOW TIME

From Formatted press \downarrow to Start MMM DD/YYYY (eg: Jan 01/2000). Press \rightarrow to position the cursor and then \downarrow or \uparrow to set the Month, Day and Year that logging will Start. Press \rightarrow to return to Start.

Press \downarrow to Start (time) and \rightarrow to position the cursor under the time column HH/MM/SS (24 hour clock in Hours/minutes/seconds, eg: 23:02:16) and then \downarrow or \uparrow to set the logging start Time. Press \rightarrow to return to Start.

Press \downarrow to Interval and \rightarrow to the Hrs column. Press \downarrow or \uparrow to select the flow logging interval. Choose from:

24 Hrs, or 12 Hrs, or 8 Hrs, or 4 Hrs, or 1 Hrs

Press \rightarrow to return to Interval. Press \downarrow and the SLT32 will report xxxxx Hrs Left indicating the amount of logging time available with your current set-up. You can also press \uparrow to return to previous menu items and make changes.

Press \downarrow to WrapAround Yes?. Press \rightarrow to Yes? and \downarrow to enable the logging wrap function. In WrapAround mode the *oldest* data will be overwritten by the *newest*. If WrapAround is not enabled the logger will stop when its memory becomes full.

Press \downarrow to Reset Log? Yes. Press \rightarrow to Yes and then \downarrow to reset the Log and erase all previous sessions and stored values. Or press \downarrow from Reset Log? to retain existing data in the Log. The SLT32 will display “xxxxx Hrs/Days Left”.

From the xxxxx Hrs Left display press ↓ to Store? Yes. Press → to Yes and then ↓ to save your Data Logging setup, or press ↓ from Store? to cancel changes made above and exit without storing changes.

From the Data Logging Store? Yes prompt the menu will return to RUN STOP SETUP. Press → to position the cursor under RUN and press ↓ to activate the Data Logger to start at your selected start Date and Time. The SLT32 will display SESS ION NO. x. Press ↓ to return to DA TA LOGG ING.

Viewing FORMATTED Data Logs on the SLT32 Display

24 Hour flow reports can be viewed directly on the SLT32 display. From RUN press → to 24 HR RE PO RT.

The 24 Hour Log Report is designed to be read one line at time using the → key. Using the ↓ or ↑ keys will return the display to the Date column.

| TODAYS DATE | DAILY TOTAL | DAILY AVERAGE | MAX FLOW | MAX FLOW TIME | MIN FLOW | MIN FLOWTIME |
|---------------|-------------|---------------|----------|---------------|----------|--------------|
| PREVIOUS DATE | “ | “ | “ | “ | “ | “ |
| PREVIOUS DATE | “ | “ | “ | “ | “ | “ |
| PREVIOUS DATE | “ | “ | “ | “ | “ | “ |
| PREVIOUS DATE | “ | “ | “ | “ | “ | “ |
| PREVIOUS DATE | “ | “ | “ | “ | “ | “ |

The current day plus the past 254 days of data can be displayed. (Greyline Logger software will display up to 1300 days of data.)

Note: In LEV EL or RAN GE modes the SLT32 will not display DA IL Y TO TA L.

Trend Data Logging - Setup

From RUN STOP SETUP press → to SETUP and then ↓ to Log Site ID 0. Press → to position the cursor under the numeral and ↓ or ↑ to change the numerals. The “Site ID” number is retained with data logging sessions to identify logs stored from different locations.

From Log Site ID press ↓ to Formatted Trend and press → to position the cursor under Trend. Then press ↓ to select Time based logging.

‘Time’ based Trend Logging

Time based logging allows you to choose Start and Stop times and a logging interval.

From Time press ↓ to Start MMM DD/YYYY (eg: Jan 01/2000). Press → to position the cursor and then ↓ or ↑ to set the Month, Day and Year that logging will Start. Press → to return to Start.

Press ↓ to Start (time) and → to position the cursor under the time column HH/MM/SS (24 hour clock in Hours/minutes/seconds, eg: 23:02:16) and then ↓ or ↑ to set the logging start Time. Press → to return to Start .

Press ↓ to Interval and → to the Sec/Min column. Press ↓ or ↑ to set the logging time interval. Choose:

| |
|--------|
| 30 Sec |
| 10 Sec |
| 5 Sec |
| 2 Sec |
| 1 Sec |
| 30 Min |
| 10 Min |
| 5 Min |
| 2 Min |
| 1 Min |

Press → to return to Interval and ↓ to Reset Log? To erase all existing data in the log press → to Yes and ↓. To keep existing data in the Log press ↓ from Reset Log? If you have made changes to the Start Date, Time or Interval, the data logger will automatically start a new “session”. The SLT32 will display “xxxxx Hrs/Days Left”.

From the xxxxx Hrs Left display press ↓ to Store? Yes. Press → to Yes and then ↓ to save your Data Logging setup, or press ↓ from Store? to cancel changes made above and exit without storing changes.

From the Data Logging Store? Yes prompt the menu will return to RUN STOP SETUP. Press → to position the cursor under RUN and press ↓ to activate the Data Logger to start at your selected start Date and Time. The SLT32 will display SESSION NO. x. Press ↓ to return to DATA LOGGING.

‘Event’ based Trend Logging

Event based logging stores data points only when a High or Low flow set point has been reached.

With cursor under Event press ↓ to HiAlM LoAlM. HiAlM will log points *above* a selectable flow rate, while LoAlM will log points *below* a selectable flow rate. Position the cursor under HiAlM or LoAlM and press ↓ to the At: prompt. Press → to the numerals column and press ↓ or ↑ to set flow alarm logging set point. Press → to return to At:

Press ↓ to Interval and → to the Sec/Min column. Press ↓ or ↑ to set the logging time interval.

Choose:

| |
|--------|
| 30 Sec |
| 10 Sec |
| 5 Sec |
| 2 Sec |
| 1 Sec |
| 30 Min |
| 10 Min |
| 5 Min |
| 2 Min |
| 1 Min |

Press → to return to Interval and press ↓ to Reset Log? To erase all existing data in the log press → to Yes and ↓. To keep existing data in the Log press ↓ from Reset Log? If you have made changes to the Start Date, Time or Interval, the data logger will automatically start a new "session". The SLT32 will display "xxxxx Hrs/Days Left".

From the xxxxx Hrs Left display press ↓ to Stores? Yes. Press → to Yes and then ↓ to save your Data Logging setup, or press ↓ from Stores? to cancel changes made above and exit without storing changes.

From the Data Logging Stores? Yes prompt the menu will return to RUN STOP SETUP. Press → to position the cursor under RUN and press ↓ to activate the Data Logger to start. The SLT32 will display SESSION NO. x. Press ↓ to return to DATA LOGGING.

Note: Greyline Logger software cannot accurately calculate totals from 'event' based log files. Use 'trend' logging format if totals must be calculated.

Logging "Sessions"

Each time you select STOP in the DATA LOGGING menu, the Data Logger stores the current data in memory as a "SESSION NO" automatically numbered from "1" to "10". If you resume logging by selecting RUN, the Data Logger will report that a new logging session is started and titled "SESSION NO xx". When you download the logger files to your PC using Greyline Logger software, each Session will open as a separate graph/table titled "Greyline Data Log xx".

Important: If you STORE instrument calibration changes under the UNITS/MODE or CALIBRATION menus, STOP the data logger and select RUN again to start a new logging Session with your new calibration values.

RS232C SERIAL OUTPUT (with optional Data Logger)

Format: 8 Bits, 1 Stop Bit, No Parity. (Baud rate may be changed under the SPECIAL FUNCTIONS menu. Factory default is 19200 baud).

Output Connector is DB9-Female. Use the cable supplied for connection to a PC Computer. Use the cable and optional Null Modem NM-DB9M/DB25M for connection to modem.

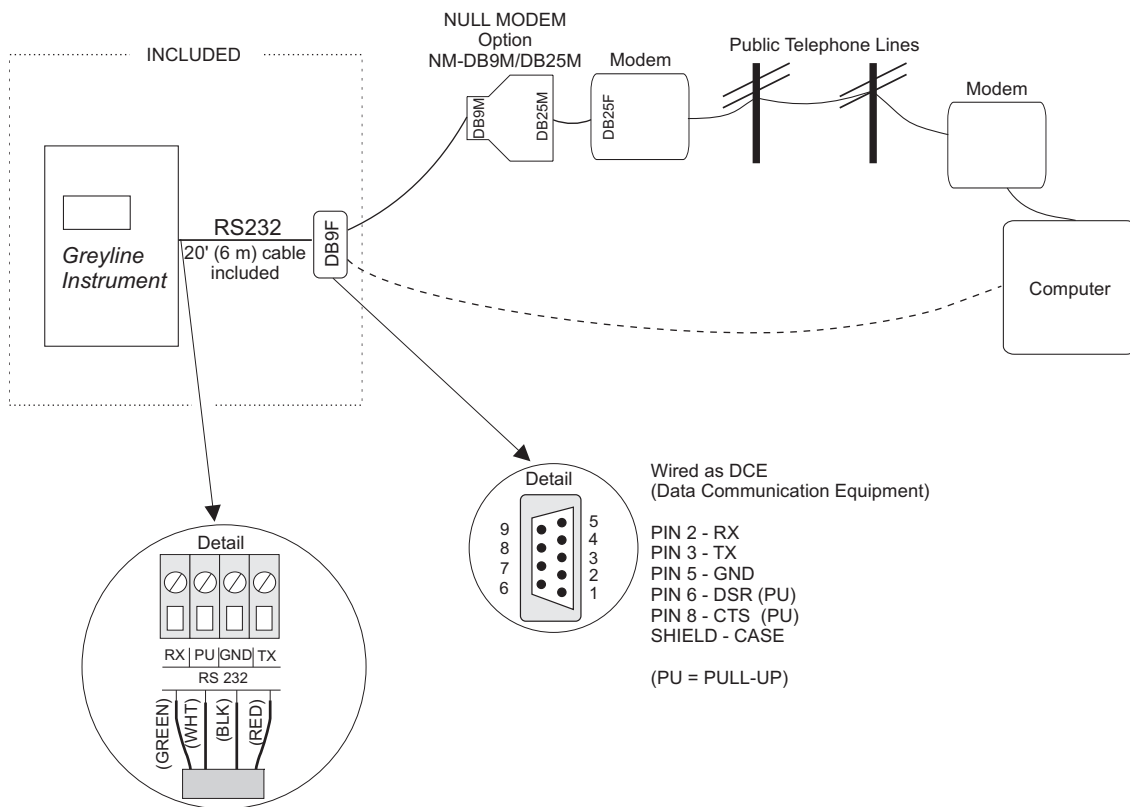

RS485 SERIAL OUTPUT
(Replaces standard RS232 Output with Data Logger option.)

Permits transfer of optional Data Logger reports on wire lengths up to 4000 ft. (1220 m).
Format: 8 Bits, 1 Stop Bit, No Parity. (Baud rate may be changed under the SPECIAL FUNCTIONS menu. Factory default is 19200 baud).

Use shielded, 4-conductor cable (Greyline cable option SC-18AWG recommended). Connect the cable shield to Ground at the SLT32 electronics enclosure and do not connect to Ground at the other end.

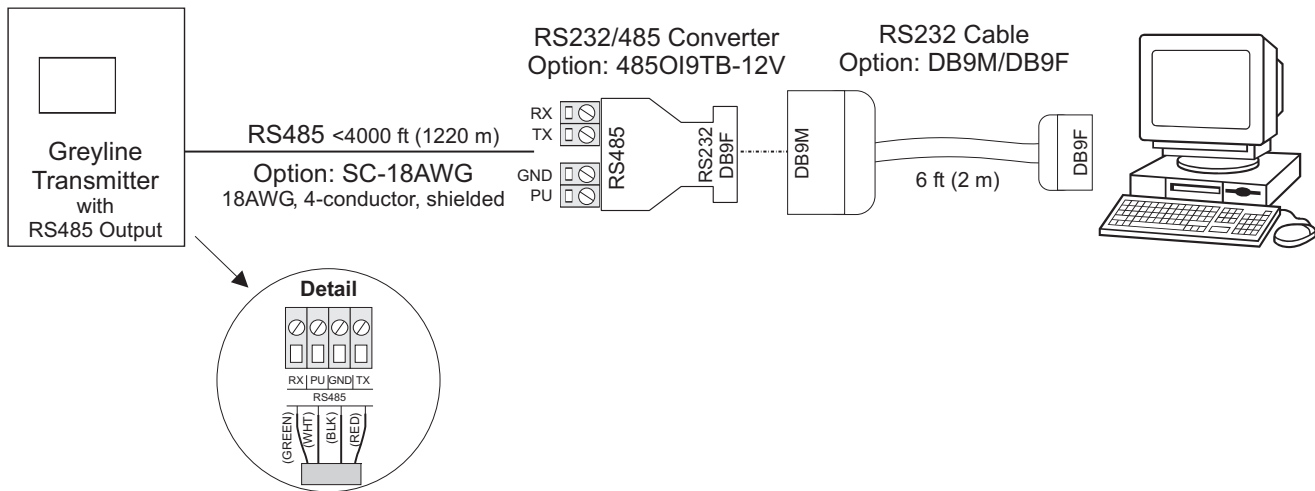

Configure the Greyline software program for RS485 communications. Under the Communications / Connection Setup menu, select 'Connected to a Greyline 485OI-12V adaptor'.

485OI9TB-12V
RS232/RS485 Converter

Use with optional RS485 output for connection to a PC computer or modem.

- Optically isolates and protects your computer's RS232 port
- Terminal block for RS485 connections
- Operates from 2400 up to 19.2K baud



DB9M/DB9F - RS232 Cable
Connects RS232/485 Converter to a PC

Cable length 6 ft. (2 m) with DB9M and DB9F connectors.

ENCLOSURE SUNSCREEN - OPTION SCR

Do not mount instrument electronics in direct sunlight. Overheating will reduce the life of electronic components and condensate may form during the heat/cool cycles and cause electrical shorts.

Note:

Exposure to direct sunlight can cause overheating and moisture condensation which will reduce the operating life of electronics.

Protect Instruments from direct sunlight with this iridite finished aluminum sun screen (Greyline Option SCR).

Seal conduit entries with caulking compound to further reduce moisture condensation.

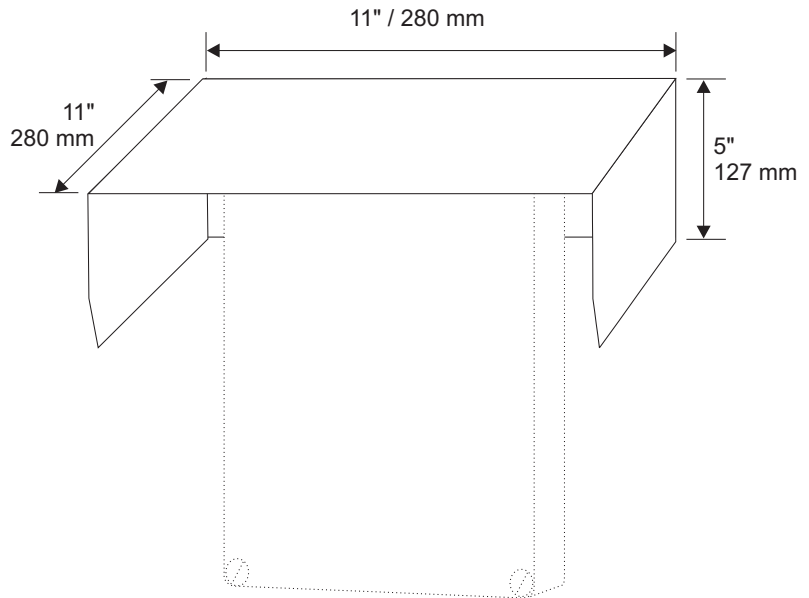

SENSOR SUNSCREEN - OPTION PZS

INSTALLATION

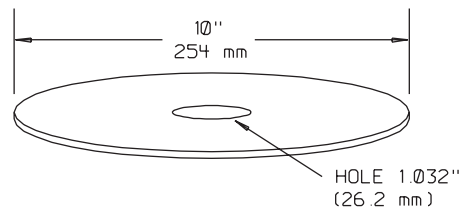
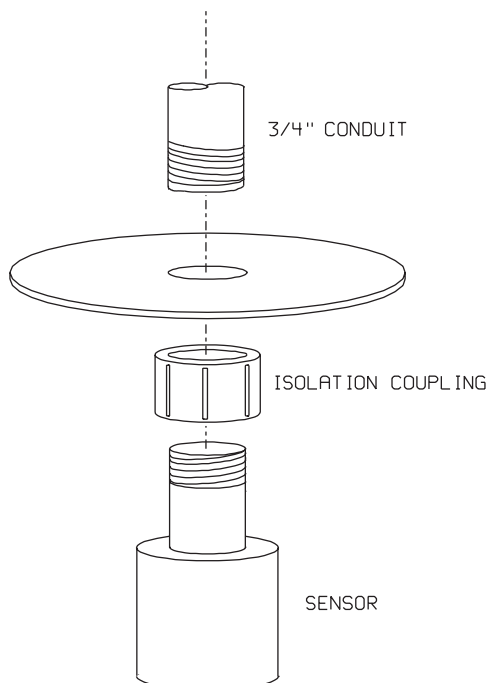

MATERIAL:
1/16" ANODIZED ALUMINUM

NOTE:
USE WHEN SENSOR IS INSTALLED IN DIRECT SUNLIGHT.

APPENDIX B - APPLICATIONS BACKGROUND

Conditions in the tank or channel where the ultrasonic sensor is installed can affect the performance, range and accuracy of the system. The following notes are for general reference. Contact Greyline Instruments or your local representative for specific information on your application.

FOAM - Solid or dense surfaces such as a smooth liquid surface will give the best echos in an ultrasonic level measuring system. Foam acts as a sound insulator and may eliminate, or reduce the strength of an echo. Measurement range may be reduced in a system where foam is present. Ultrasonics are not recommended where thick dense foam is continually present. Intermittent or thin layers of light foam (1/8 in. or less) can generally be disregarded. Use a stilling well in open channel applications.

LIQUIDS - The SLT32 is ideal to monitor tank liquid level or inventory. Caustic, corrosive or very viscous liquids can be monitored without contacting the liquid.

SOLIDS - The SLT32 will measure most granular material and powders as well as liquids. Powders will not generally provide the same echo strength as liquids. Therefore maximum expected range should be reduced to approximately 20 feet (6 m) for powders. There are many exceptions to this rule and installation of a test system is recommended when in doubt.

DUST - Any obstructions to the sound will affect performance of the system. In silo's where heavy concentrations of dust are expected ultrasonics may not work. Where moderate dust is encountered care should be taken to mount the sensor in a position where dust accumulation will be minimized and where the sensor can be cleaned if necessary.

SENSOR TEMPERATURE - The standard sensor model PZ32T supplied with each Level & Flow Monitor includes a built-in temperature sensor. The SLT32 automatically compensates for temperature fluctuations to retain high accuracy. Note the operating temperature ranges listed in the product specifications section. Do not exceed the sensor temperature ratings or damage may occur.

ELECTRONICS TEMPERATURE - Note operating temperature ranges listed in the product specifications. Temperatures higher than the maximum shown can reduce the operating life of the electronics. Moisture condensation from those temperatures below the range shown can also damage electronics components. In cold or outdoor environments the optional factory-installed enclosure heater and thermostat is recommended.

NOISE - Because the SLT32's sensor operates at high sound frequency, regular process noise or vibration will not affect the system. Sensors installed in close proximity to one another in the same tank may "cross-talk" and should be synchronized.

VAPOUR - May affect but it can be compensated for by calibration in-situ. Severe vapour stratification can cause false echoes. Variable vapour cannot be compensated.

CHEMICAL COMPATIBILITY - The SLT32 is constructed of very durable materials with broad compatibilities. Tank contents should be checked for their compatibility with PVC. An all-teflon sensor is available for corrosive applications.

| CONVERSION GUIDE | | |
|-------------------|--------------------|-----------------|
| FROM | TO | MULTIPLY BY |
| US GALLONS | CUBIC FEET | 0.1337 |
| US GALLONS | IMPERIAL GALS | 0.8327 |
| US GALLONS | LITRES | 3.785 |
| US GALLONS | CUBIC METERS | 0.003785 |
| LITRES/SEC | GPM | 15.85 |
| LITRES | CUBIC METERS | 0.001 |
| BARRELS | US GALLONS | 42 |
| BARRELS | IMPERIAL GALS | 34.9726 |
| BARRELS | LITRES | 158.9886 |
| INCHES | MM | 25.4 |
| DEGREES F | DEGREES C | (°F-32) x 0.556 |
| POUNDS | KILOGRAMS | 0.453 |
| PSI | BAR | 0.0676 |
| FOOT ² | METER ² | 0.0929 |

VOLUME CALCULATION FOR ROUND TANKS: $3.142 \times R^2 \times H$

R = TANK RADIUS ($\frac{1}{2}$ TANK DIAMETER)

H = TANK HEIGHT

SPECIFICATIONS

Electronics Enclosure: NEMA4X (IP 66), watertight and dust tight, fiberglass with clear, shatterproof hinged Lexan cover

Accuracy: 0.25% F.S.,
Repeatability: 0.1% F.S.,
Linearity: 0.1%F.S.

Display: Flow/Level Values: 3/4" / 19 mm high, 4 digit LCD
Menu/Status/Totalizer:
16 digit LCD alphanumeric

Programming: 3-button keypad with Menu selection. Calibration parameters are permanent when Stored (even through power interruptions)

Power Input: 100-130VAC, 50/60 Hz, (7.2 W max.)
Optional: 200-260VAC, 50/60 Hz, (7.2 W max.)
Optional: 9-36VDC (5.2 W max.)

Output: Isolated 4-20mA, 1000 ohm load maximum

Control Relay: Qty 3, rated 5 ampere SPDT

Temperature Compensation: Automatic, temperature probe built in to level Sensor

Electrical Surge Protection: Sensor, 4-20mA, AC power input

Operating Temperature (electronics): -5 to 140°F (-20 to 60°C). Optional Enclosure Heater recommended for condensation protection below 32°F (-1°C)

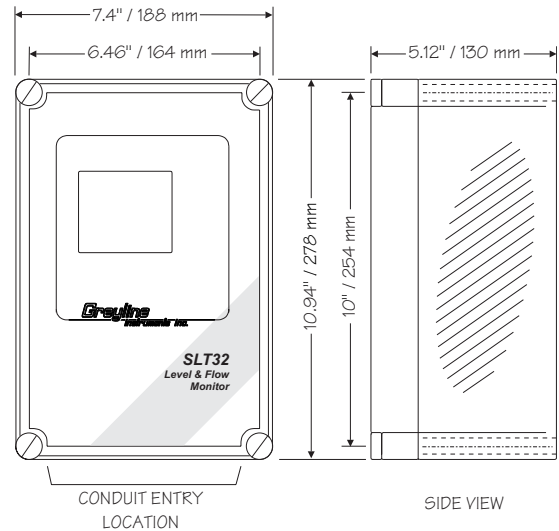

ENCLOSURE

Standard Sensor PZ32T

Maximum Range: 32 ft. (10 m)

Deadband (blanking): Programmable, minimum 12" (305 mm)

Beam Angle: 8° at 3 DB

Temperature Compensation: Automatic, continuous

Operating Frequency: 42 KHz

Exposed Materials: PVC and Teflon

Operating Temperature: -40° to 150°F (-40° to 65°C)

Operating Pressure: 20 psi (1.35 Bar) maximum

Mounting: 3/4" NPT (PVC isolation coupling supplied)

Sensor Cable: RG62AU coaxial, 25 ft. (7.6 m) standard

Hazardous Rating: with optional Intrinsic Safety Barrier: CSA, Class I,II,III, Div. I,II, Groups C,D,E,F,G

Note: Max Range reduced to 25 ft (7.6 m) with ISB option.

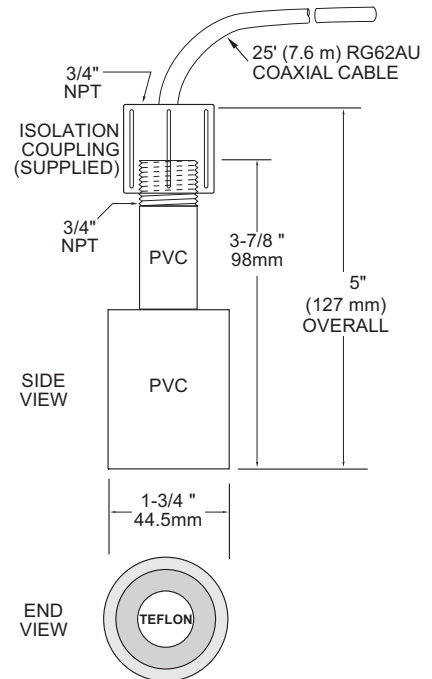

Optional Sensor PZ32TE

- Maximum Range:** 32 ft. (10 m)
- Deadband (blanking):** Programmable, minimum 12" (305 mm)
- Beam Angle:** 8° at 3 DB
- Temperature Compensation:** Automatic, continuous
- Operating Frequency:** 42 KHz
- Exposed Materials:** Teflon
- Operating Temperature:** -40° to 170°F (-40° to 76°C)
- Operating Pressure:** 20 psi (1.35 Bar) maximum
- Mounting:** 3/4" NPT (Teflon isolation coupling supplied)
- Sensor Cable:** RG62AU coaxial, 25 ft. (7.6 m) standard
- Hazardous Rating:** with optional Intrinsic Safety Barrier: CSA, Class I,II,III, Div. I,II, Groups C,D,E,F,G,
Note: Max Range reduced to 25 ft (7.6 m) with ISB option.

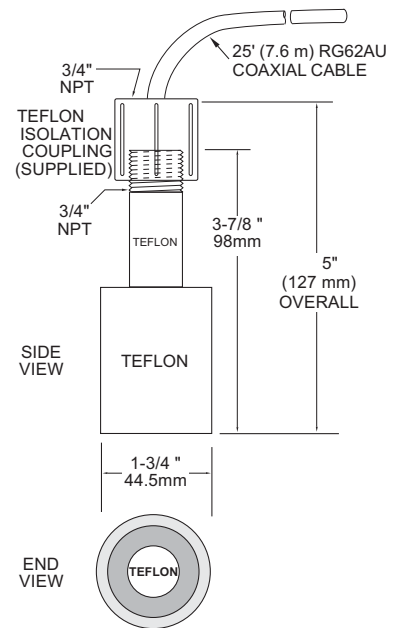

Optional PZ52T

- Maximum Range:** 50 ft. (15.6 m)
- Deadband (blanking):** Programmable, minimum 16"(406mm)
- Beam Angle:** 8° at 3 DB
- Temperature Compensation:** Automatic, continuous
- Operating Frequency:** 40 KHz
- Exposed Materials:** PVC and Teflon
- Operating Temperature:** -40 to 150°F (-40 to 65°C)
- Operating Pressure:** 20 psi (1.35 Bar) maximum
- Mounting:** 3/4" NPT (Isolation Coupling supplied)
- Sensor Cable:** RG62Au coaxial, 50 ft. (15 m) standard
- Hazardous Rating:** with optional Intrinsic Safety Barrier: CSA, Class I,II,III, Div. I,II, Groups C,D,E,F,G,
Note: Max Range reduced to 32 ft (10 m) with ISB option.

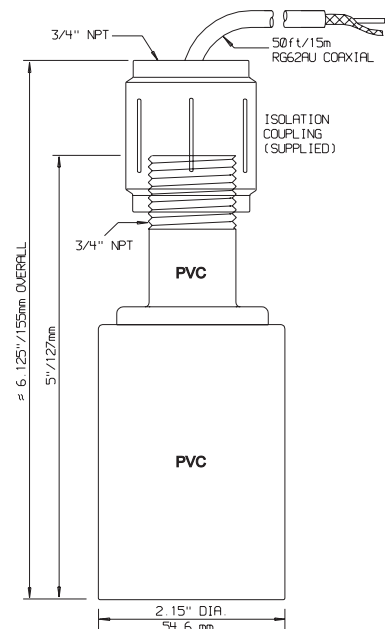

Optional PZ15

- Maximum Range:** 15 ft (4.57 m)
- Minimum Range (Deadband):** 8" (203.2 mm)
- Operating Frequency:** 92 KHz
- Beam Angle:** 8°
- Operating Temperature:** -40° to 150° (-40° to 65°C)
- Temperature Compensation:** Automatic, continuous
- Max. Operating Pressure:** 20 psi (1.35 bar)
- Sensor Face:** PVC
- Sensor Body:** PVC
- Mounting:** 3/4" NPT
- Cable Length:** 25 ft. (7.6 m) continuous RG62AU coaxial. Optional 50 ft. (15 m) continuous
- Max. Cable Length:** 500 ft. (152 m) RG62AU coaxial (splice)
- Hazardous Rating:** CSA rated Intrinsically Safe Class I, Groups C,D, Class II, Groups E,F,G with Optional Intrinsic Safety Barrier.

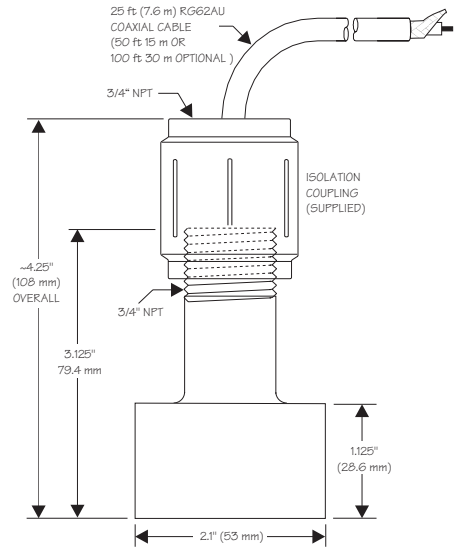

Optional PZ12T_F

- Maximum Range:** 12 ft (3.66 m)
- Minimum Range (Deadband):** 8"(203.2 mm)
- Operating Frequency:** 92 KHz
- Beam Angle:** 8°
- Operating Temperature:** -40° to 150° (-40° to 65°C)
- Temperature Compensation:** Automatic, continuous
- Max. Operating Pressure:** 20 psi (1.35 bar)
- Sensor Face:** Teflon
- Sensor Body:** PVC
- Mounting:** 3/4" NPT
- Cable Length:** 25 ft. (7.6 m) continuous RG62AU coaxial. Optional 50 ft. (15 m) continuous
- Max. Cable Length:** 500 ft. (152 m) RG62AU coaxial (splice)
- Hazardous Rating:** CSA rated Intrinsically Safe Class I, Groups C,D, Class II, Groups E,F,G with optional Intrinsic Safety Barrier.

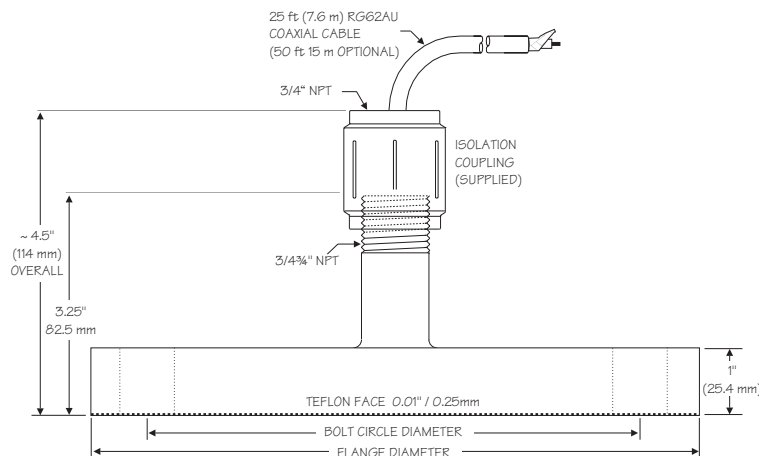

Optional PZ34

- Maximum Range:** 32 ft. (10 m)
- Minimum Range (Deadband):** 16" (406.4 mm)
- Operating Frequency:** 46 KHz
- Beam Angle:** 8°
- Temperature Compensation:** Automatic, continuous
- Operating Temperature:** -40° to 150°F (-40° to 65°C)
- Maximum Operating Pressure:** 20 psi (1.35 Bar)
- Exposed Materials:** PVC
- Sensor Mounting:** 3/4" NPT
- Maximum Cable Length:** 500 ft (152 m)
- Optional Hazardous Rating:** CSA rated Intrinsically Safe Class I, Groups C,D, Class II, Groups E,F,G with optional Intrinsic Safety Barrier.

Note: Max Range reduced to 25 ft (7.8 m) with ISB option.

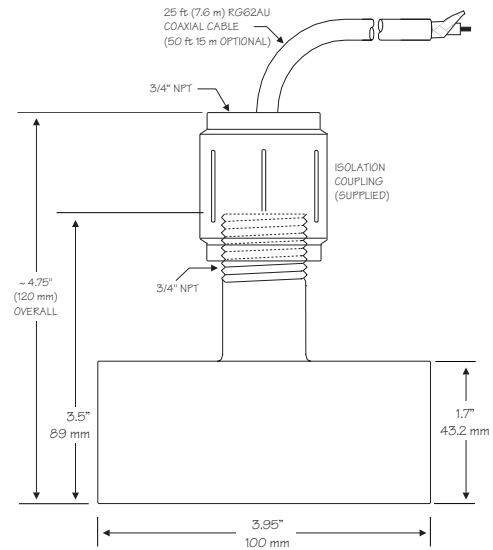

Optional PZ34T_F

- Maximum Range:** 32 ft. (10 m)
- Minimum Range (Deadband):** 16" (406.4 mm)
- Operating Frequency:** 46 KHz
- Beam Angle:** 8°
- Temperature Compensation:** Automatic, continuous
- Operating Temperature:** -40° to 150°F (-40° to 65°C)
- Maximum Operating Pressure:** 20 psi (1.35 Bar)
- Sensor Face:** Teflon
- Sensor Body:** PVC (not exposed to tank contents)
- Cable Length:** 25 ft. (7.6 m) continuous RG62AU coaxial Optional 50 ft. (15 m) continuous
- Maximum Cable Length:** 500 ft (152 m) RG62AU coaxial (splice)
- Hazardous Rating:** CSA rated Intrinsically Safe Class I, Groups C,D, Class II, Groups E,F,G with optional Intrinsic Safety Barrier.

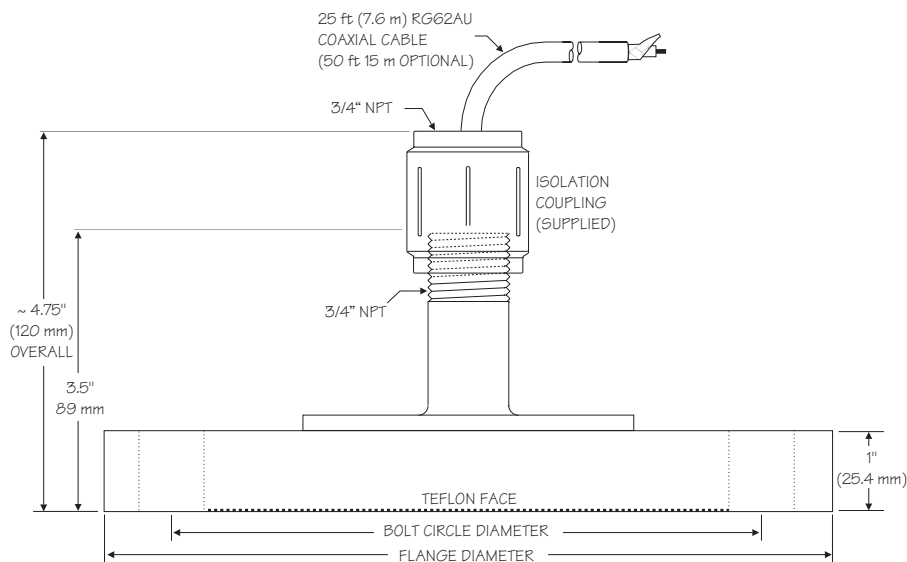

CALIBRATION WORKSHEET - Level Mode

for Horizontal Round Tanks (HRT) and Vertical Tanks

(SLT32 reads) A = _____

Program SLT32 to show RANGE via:

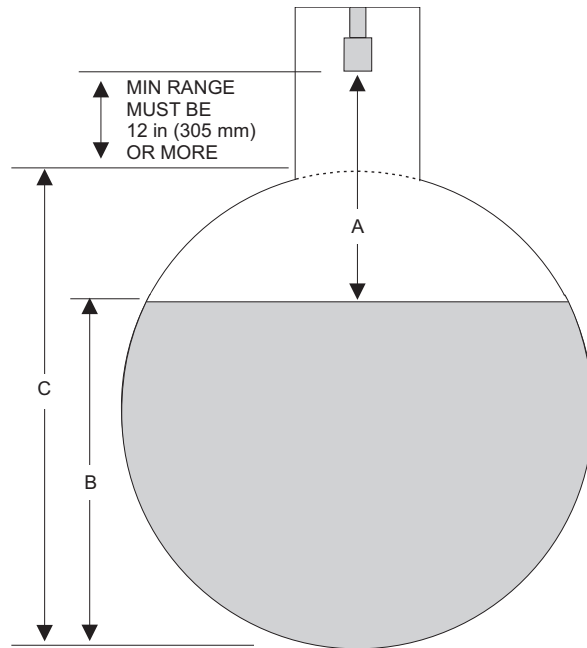
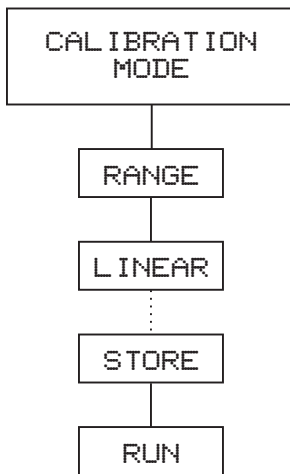

(DIP STICK) B = _____

(INSIDE DIA.) C = _____

Program MIN RANGE then
MAX RANGE via:

| | | | | |
|-----|---|-----|---|---------------|
| A | + | B | = | MAX RANGE |
| ___ | + | ___ | = | _____ |
| A | + | B | - | C = MIN RANGE |
| ___ | + | ___ | - | _____ |

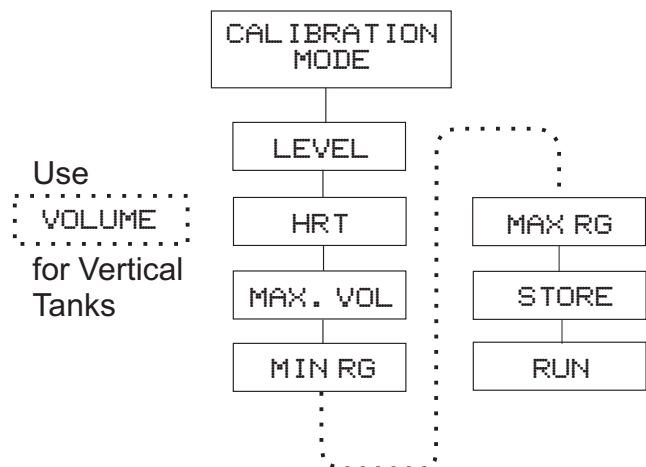

NOTE: The SLT32 will not detect targets beyond user entered MaxRg.

CALIBRATION WORKSHEET - Flow Mode
for Open Channel Flow through Flume and Weirs

MAX RANGE A = _____
(SLT32 READS)

To display RANGE press **↓↓** from RUN

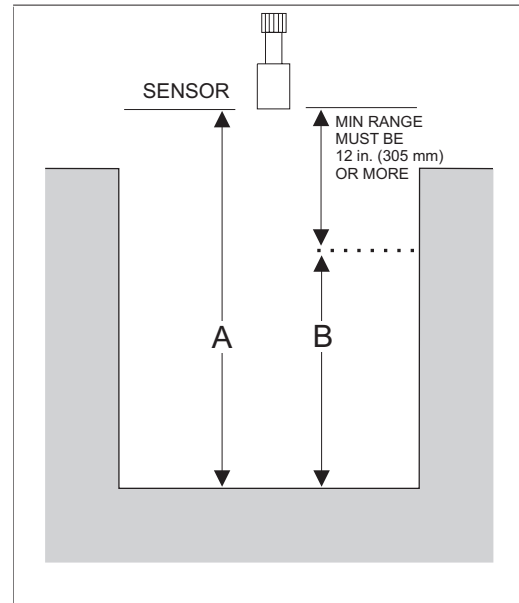
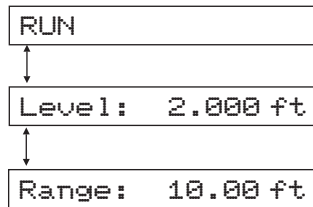

MAX HEAD B = _____
(Height at MAX Flow)

A - B = MIN RANGE
____ - ____ = _____

Program MIN RANGE then
MAX RANGE via:

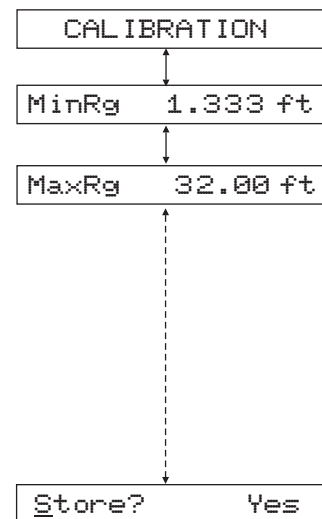

NOTE: The SLT32 will not detect targets beyond the user entered MaxRg.

